

# FOUNTAINDALE PUBLIC LIBRARY DISTRICT BOARD OF LIBRARY TRUSTEES

February 20, 2025 | 7 p.m.

300 West Briarcliff Road | Bolingbrook | Margaret J. "Peggy" Danhof Board Room

View the meeting online via YouTube: <https://www.youtube.com/live/5lrjb-cC4a0>

- 1. Call to Order and Roll Call of Trustees**
- 2. Pledge of Allegiance**
- 3. Approval of Agenda**
- 4. Minutes for Approval**
  - a. Board Meeting – January 16, 2025
  - b. Executive Session – January 16, 2025
- 5. Employee Recognition**
  - a. Ann Burkiewicz – 20 Years
- 6. Comments from the Public**
- 7. Friends of the Library**
- 8. New Business – Action Items**
  - a. Approval to Seek Bids for Parking Lot Project
  - b. Approval to Seek Bids for Monument Sign Project
  - c. Approval of Appointment of 2025 Executive Director Evaluation Liaisons
- 9. Library Projects**
- 10. Correspondence**
- 11. Treasurer's Report**
- 12. Bills for Approval**
  - a. Bills Paid Report – February, 2025
  - b. Bills Payable Report – February, 2025
- 13. Director's Report – January, 2025**
- 14. Unfinished Business**
- 15. Reports**
  - a. Building
  - b. Finance
  - c. Strategic
  - d. Internal Board Operations
- 16. Agenda Building for Next Meeting**
- 17. Announcements**
- 18. Adjournment**

## February 2025 Agenda Background

Paul Mills

### 8. New Business – Action Items

- a. Approval to Seek Bids for Parking Lot Project

We are ready to seek bids to replace and resolve drainage issues in our parking lot, add electrical vehicle charging infrastructure, and redo the entire lot. Architect Ron McGrath from Tria will discuss this at the board meeting.

**Suggested Motion: Motion to approve seeking bids for the Parking Lot Project.**

- b. Approval to Seek Bids for Monument Sign Project

We are ready to seek bids to replace the existing digital sign on Briarcliff with a new one. Architect Ron McGrath from Tria will attend the board meeting to discuss this.

**Suggested Motion: Motion to approve seeking bids for the Monument Sign Project.**

- c. Approval of Appointment of 2025 Executive Director Evaluation Liaisons

My anniversary is in July; it is time to prepare for my annual evaluation. The Evaluation Liaisons will be charged with organizing the evaluation process.

With approval by the Board, President Bermejo has named Trustee TBD and Trustee TBD the 2025 Executive Director Evaluation Liaisons.

**Suggested Motion: Motion to approve the appointment of the 2025 Executive Director Evaluation Liaisons.**

**MINUTES OF A REGULAR MEETING OF THE BOARD OF TRUSTEES OF  
THE FOUNTAINDALE PUBLIC LIBRARY DISTRICT  
WILL AND DUPAGE COUNTIES, ILLINOIS  
HELD JANUARY 16, 2025  
BOLINGBROOK, ILLINOIS**

A meeting of the Board of Trustees of the Fountaindale Public Library District, Will and DuPage Counties, Illinois was held in the Margaret J. "Peggy" Danhof Board Room, 300 West Briarcliff Road, Bolingbrook, Illinois on Thursday, January 16, 2025 at 7 p.m.

**CALL TO ORDER**

The meeting was called to order at 7 p.m. by President Celeste Bermejo.

**ROLL CALL**

The roll was called by recorder, Juanita Lennon, and a quorum was established.

**PRESENT**

Present at roll call were Bobby Armstrong, Marcelo Valencia, Kathryn Spindel, Sarah Siska, Jim Daunis Jr. and Celeste Bermejo.

**ABSENT**

Trustee Meraj Alam

Alam entered at 7:07 p.m.

## **FOUNTAINDALE STAFF PRESENT**

The following staff was present: Paul Mills, Juanita Lennon, Tana Petrov, Carolyn Boyer and Sarah Saltzman.

Nancy Korczak was present online.

## **PUBLIC PRESENT**

The following public was present: Jody Hargett, Jennie Mills, Dora Dosheva, Peter Petrov, Alexander Petrov.

## **AGENDA APPROVAL**

Following the Pledge of Allegiance, Bermejo asked for a motion to approve the agenda. A motion was made by Daunis, seconded by Valencia.

AYES: Armstrong, Valencia, Spindel, Siska, Daunis, Bermejo

NAYES: None

ABSENT: Alam

## **MINUTES OF THE BOARD MEETING – DECEMBER 19, 2024**

The minutes of the board meeting held December 19, 2024 were presented. A motion to approve the minutes was made by Daunis, seconded by Armstrong. Minutes were approved as read.

AYES: Armstrong, Valencia, Spindel, Siska, Daunis, Bermejo

NAYES: None

ABSENT: Alam

## **EMPLOYEE RECOGNITION**

President Bermejo recognized Tana Petrov for her five years of service and presented her with a certificate award. Bermejo also recognized Juanita Lennon for her 15 years of service and presented her with a certificate award.

## **COMMENTS FROM THE PUBLIC**

No comments were made.

## **FRIENDS OF THE LIBRARY**

Jody Hargett gave an update for the Board. Hargett reported that sales have been slow at both the Book Cellar and The Nook due to the cold weather. Next Tuesday, the Friends will host a pop-up cookbook sale in the lobby to coincide with the Chef Maddox cooking program.

## **NEW BUSINESS**

### **Approval of Intergovernmental Agreement Between Fountaindale Public Library District and Will County Regarding Ballot Collection Box Drop-Off Site**

Mills reviewed the agreement's features. This agreement would remain in effect unless canceled by either the library or the county and would provide for a ballot collection drop-off box to be in the library.

A motion to approve the Intergovernmental Agreement between Fountaindale Public Library District and Will County regarding the Ballot Collection Box Drop-off site was made by Spindel, seconded by Valencia.

AYES: Armstrong, Valencia, Spindel, Siska, Alam, Daunis, Bermejo

NAYES: None

ABSENT: None

### **Approval of Resolution 2025-1 – Resolution Authorizing Intervention in Certain Tax Appeal Cases**

Mills explained that this resolution would continue to authorize Tressler, LLP to represent the library in tax appeal cases.

A motion to approve Resolution 2025-1, Resolution authorizing intervention in certain tax appeal cases was made by Daunis, seconded by Valencia.

AYES: Armstrong, Valencia, Spindel, Siska, Alam, Daunis, Bermejo

NAYES: None

ABSENT: None

### **Approval of Request to Travel for Trustees to Attend 2025 American Library Association Annual Conference in Philadelphia, PA – June 26–30, 2025**

A motion to approve the request to travel for Trustees to attend the 2025 American Library Association Annual Conference in Philadelphia, Pennsylvania in June 26-30, 2025 was made by Alam, seconded by Valencia.

AYES: Armstrong, Valencia, Spindel, Siska, Alam, Daunis, Bermejo

NAYES: None

ABSENT: None

### **Approval of Request to Travel for Executive Director to Attend 2025 American Library Association Annual Conference in Philadelphia, PA – June 26–30, 2025**

A motion to approve the request to travel for the Executive Director to attend the 2025 American Library Association Annual Conference in Philadelphia, Pennsylvania in June 26-30, 2025 was made by Alam, seconded by Valencia.

AYES: Armstrong, Valencia, Spindel, Siska, Alam, Daunis, Bermejo

NAYES: None

ABSENT: None

## **LIBRARY PROJECTS**

Mills reported that work on the interior lighting project has resumed this week and should be completed soon.

Tria Architect Ron McGrath will be meeting soon with the Building Liaisons regarding the parking lot and the monument sign.

## **CORRESPONDENCE**

None.

## **TREASURER'S REPORT**

The Treasurer's Report for December, 2024 was presented by Treasurer Spindel and will be filed for audit.

## **BILLS FOR APPROVAL**

### **Bills Paid Report – January, 2025**

Bills paid for the month of January in the amount of \$67,361.32 were presented for approval. Motion to approve was made by Valencia, seconded by Daunis.

AYES: Armstrong, Valencia, Spindel, Siska, Alam, Daunis, Bermejo

NAYES: None

ABSENT: None

### **Bills Payable Report – January, 2025**

Bills payable for the month of January in the amount of \$3,405,591.16 was presented for approval. Motion to approve was made by Spindel, seconded by Daunis.

AYES: Armstrong, Valencia, Spindel, Siska, Alam, Daunis, Bermejo

NAYES: None

ABSENT: None

## **DIRECTOR'S REPORT – DECEMBER, 2024**

Executive Director Mills reported that he will be the recipient of the 2025 Bolingbrook Chamber of Commerce Business Leader of the Year at the Best of Bolingbrook Business Awards in April.

Mills informed the Board that he will have jury duty the first week of February.

Several community events are coming up including Dancing with the Stars of Bolingbrook featuring our very own Trustee Armstrong. Armstrong is raising funds for the Friends of Fountaindale Library.

The kick-off fundraiser event for the Dolly Parton Imagination Library is on January 30.

The State of the Village is on Thursday, February 13 at the Bolingbrook Golf Club.

The Valley View Educational Educational Foundation Annual Dinner & Auction is on Friday, March 7.

The Best of the Bolingbrook Business Awards is on Thursday, April 17.

## **UNFINISHED BUSINESS**

None.

## **REPORTS**

### **Building**

None.

### **Finance**

The Liaisons plan to meet at the end of the month.

### **Strategic Plan**

The Liaisons plan on meeting at the end of February.



## **Internal Board Operations**

None.

## **AGENDA BUILDING FOR THE NEXT MEETING**

None.

## **ANNOUNCEMENTS**

The Lions Club's Meat Raffle will be held on Saturday, February 1 from 1–5 p.m. at Tailgators.

The Lions Club and the Knights of Columbus will host the St. Patrick's Dinner Dance on Saturday, March 15 from 6–10 p.m. at The Levy Center. Trustee Alam will be sponsoring the photobooth for the event.

The Rotary Club will host their annual Mac & Cheese Cook-off Fundraiser on Saturday, March 8 at New Life Church.

The Rotary Club's MLK Day of Service will be on Monday, January 20 at the BRAC.

## **EXECUTIVE SESSION**

A motion was made by Valencia, seconded by Daunis, to enter Executive Session at 7:32 p.m. for 5 ILCS 120/2 (c) (21) "Discussion of minutes of meetings lawfully closed under this Act, whether for purposes of approval by the body of the minutes or semi-annual review of the minutes as mandated by Section 2.06."

AYES: Armstrong, Valencia, Spindel, Siska, Alam, Daunis, Bermejo

NAYES: None

ABSENT: None

A motion was made by Valencia, seconded by Daunis, to return to Open Session at 7:38 p.m.

## **OPEN SESSION**

### **APPROVAL OF REPORT ON REVIEW OF CLOSED MEETING MINUTES**

Bermejo reported that the consensus was to keep all closed meeting minutes closed.

A motion to approve the report on the review of closed Executive Session Minutes and for the minutes to remain closed was made by Alam, seconded by Daunis.

AYES: Armstrong, Valencia, Spindel, Siska, Alam, Daunis, Bermejo

NAYES: None

ABSENT: None

### **ADJOURNMENT**

A motion to adjourn the meeting at 7:39 p.m. was made by Daunis, seconded by Valencia.

AYES: Armstrong, Valencia, Spindel, Siska, Alam, Daunis, Bermejo

NAYES: None

ABSENT: None

Approved: \_\_\_\_\_  
Robert Armstrong, Secretary

\_\_\_\_\_  
Celeste M. Bermejo, President

# Budget Estimate

February 10, 2025

Fountaindale Public Library  
2025 Site Renovations

Architect's Project #: 23-043



## Construction Costs

<u>Item</u>	<u>Budget Totals</u>
Site Work (see attached breakdown)	\$940,426.25
Additional PVC Conduit for future charging stations	\$7,590.00
Radiant Tubing	\$36,601.74
<hr/>	
<b>Total For All Scope of Work</b>	<b>\$984,617.99</b>



CREATIVITY BEYOND ENGINEERING

PROJECT	FOUNTAINDALE LIBRARY
LOCATION	BOLINGBROOK, IL
PROJECT NUMBER	3230106
PROJECT MANAGER	MILETIC
DATE	2/3/2025

**CIVIL ENGINEERS OPINION OF PROBABLE COST  
FOUNTAINDALE LIBRARY 2025 SITE IMPROVEMENTS**

ITEM #	ITEM DESCRIPTION	QTY.	UNIT	UNIT PRICE	EXTENSION
1	Construction Entrance	1	Lump Sum	\$2,000.00	\$2,000.00
2	Silt Fence	70	LF	\$5.00	\$350.00
3	Inlet Protection Bag	9	EACH	\$150.00	\$1,350.00
4	Erosion Control Blanket	350	SY	\$2.50	\$875.00
5	Onsite Cut and Fill Rotation - Grading	600	CY	\$25.00	\$15,000.00
6	Spoil Excavation and Hauloff (CCDD)	300	CY	\$60.00	\$18,000.00
7	Sidewalk Removal and Hauloff, Base stone remains	3789	SF	\$5.00	\$18,945.00
8	Curb and Gutter Removal and Hauloff	167	LF	\$15.00	\$2,505.00
9	Asphalt and Base Removal and Hauloff, Full Depth	2341	SY	\$50.00	\$117,050.00
10	1.5" Asphalt Mill and Hauloff	7783	SY	\$5.00	\$38,915.00
11	Remove rip-rap	10	CY	\$60.00	\$600.00
12	6" Storm Pipe Removal	20	LF	\$10.00	\$200.00
13	Storm Structure Removal	1	EACH	\$800.00	\$800.00
14	Bollard Sign Removal	3	EACH	\$250.00	\$750.00
15	Temporary Construction Fence	1900	LF	\$10.00	\$19,000.00
16	8" Aggregate Base Course, Type B	1850	SY	\$20.00	\$37,000.00
17	10" Aggregate Base Course, Type B	492	SY	\$25.00	\$12,300.00
18	2.25" HMA Binder Course, IL-19.0,N50	1850	SY	\$16.00	\$29,600.00
19	2.5" HMA Binder Course, IL-19.0,N50	492	SY	\$18.00	\$8,856.00
20	1.5" HMA Surface Course, IL-9.0, Mix "C", N50	10124	SY	\$12.50	\$126,550.00
21	5" PCC Sidewalk	3789	SF	\$10.00	\$37,890.00
22	B6.12 Concrete Curb and Gutter	167	LF	\$45.00	\$7,515.00
23	Segmental Concrete Block Retaining Wall	773	SF Face	\$100.00	\$77,300.00
24	4" Perforated Underdrain	200	LF	\$30.00	\$6,000.00
25	18" RCP, Class IV	841	LF	\$80.00	\$67,280.00
26	24" RCP, Class III	73	LF	\$100.00	\$7,300.00
27	2' Diameter Concrete Inlet, Frame, & Grate	1	EACH	\$2,500.00	\$2,500.00
28	4' Diameter Concrete Manhole, Frame, & Grate	9	EACH	\$3,700.00	\$33,300.00
29	24" Concrete Flared End Section	2	EACH	\$2,500.00	\$5,000.00
30	2" PVC Conduit	900	LF	\$5.00	\$4,500.00
31	Electric Handhole, Concrete	2	EACH	\$2,500.00	\$5,000.00
32	Trench Backfill	900	LF	\$2.50	\$2,250.00
33	4" Paint Pavement Marking	5000	LF	\$1.50	\$7,500.00
34	Painted Letters And Symbols	17	EACH	\$150.00	\$2,550.00
35	ADA Warning Panels	15	EACH	\$500.00	\$7,500.00
36	Remove and Replace Bike Racks	8	EACH	\$600.00	\$4,800.00
37	Bollard Signs	3	EACH	\$900.00	\$2,700.00
38	4' Tall Aluminum Fence	177	LF	\$50.00	\$8,850.00
39	Lawn Seeding (IDOT Class 1)	0.59	ACRE	\$4,000.00	\$2,360.00
40	Shrubs	40	EACH	\$150.00	\$6,000.00
41	Grasses/Perennials	144	EACH	\$25.00	\$3,600.00
<b>SUBTOTAL COST</b>					<b>\$752,341.00</b>
	General Contractor OH & P		15%		\$112,851.15
	Construction Contingency		10%		\$75,234.10
<b>GRAND TOTAL COST</b>					<b>\$940,426.25</b>

Assumptions:

- All items include labor and material
- Opinion of Probable Cost is based on Engineer's experience and shall not be considered accurate to current market rates. Consult a contractor for more accurate cost estimate.
- Quantities are based off the 12-069-24 preliminary plans by raSmith



# FOUNTAINDALE PUBLIC LIBRARY DISTRICT

## 2024 MONUMENT SIGN RENOVATIONS:

300 W. BRIARCLIFF RD., BOLINGBROOK, IL 60440

TRIA PROJECT#: 24-036

ARCHITECT:  
**TRIA ARCHITECTURE, INC.**

Illinois Office: 901 McClintock Drive, Suite 100  
Burr Ridge, Illinois 60527

Indiana Office: 436 Sand Creek Drive N, Suite 105  
Chesterton, Indiana 46304

Phone: 630.455.4500 Fax: 630.455.4040  
www.TriaArchitecture.com

### GENERAL BUILDING CODE REQUIREMENTS

**BUILDING CODES REFERENCED:**

- 2018 INTERNATIONAL BUILDING CODE WITH AMENDMENTS
- CURRENT ILLINOIS ENERGY CONSERVATION CODE
- 2018 INTERNATIONAL FUEL GAS CODE WITH AMENDMENTS
- 2018 INTERNATIONAL MECHANICAL CODE WITH AMENDMENTS
- 2017 NATIONAL ELECTRIC CODE WITH AMENDMENTS
- CURRENT STATE OF ILLINOIS PLUMBING CODE
- CURRENT ILLINOIS ACCESSIBILITY CODE

OCCUPANCY CLASSIFICATION: NA  
TYPE OF CONSTRUCTION: NA

DESIGN FIRM REGISTRATION:  
TRIA ARCHITECTURE, INC.  
ILLINOIS DEPARTMENT OF PROFESSIONAL REGULATIONS: #184-004118

### DRAWING INDEX

T1.00 TITLE SHEET, SITE LOCATION MAP, DRAWING INDEX, AND GENERAL BUILDING CODE REQUIREMENTS

**ARCHITECTURAL:**

- A0.10 EXISTING PLAN DETAILS AND ELEVATIONS
- A1.10 PLAN DETAILS AND ELEVATIONS
- A1.11 SECTIONS AND DETAILS

### BOARD OF TRUSTEES

PRESIDENT	CELESTE M. BERMEJO
VICE PRESIDENT	MARCELO VALENCIA
SECRETARY	BOBBY ARMSTRONG
TREASURER	KATHRYN J. SPINDEL
TRUSTEE	MERAJ ALAM
TRUSTEE	JIM DAUNIS JR.
TRUSTEE	SARAH M. SISKA

### STATEMENT OF COMPLIANCE

THESE CONSTRUCTION DOCUMENTS DATED, MONTH XX, YEAR, AS THEY RELATE TO THE SCOPE OF SERVICES AGREED UPON BETWEEN TRIA ARCHITECTURE, INC. AND CLIENT NAME FOR THE PROJECT NAME WERE REVIEWED BY ME AND WERE FOUND TO BE, TO THE BEST OF MY KNOWLEDGE, IN COMPLIANCE WITH THE RELEVANT REQUIREMENTS OF THE ILLINOIS ACCESSIBILITY CODE (71 ILL. ADM. CODE 400).

I HEREBY CERTIFY THAT THESE PLANS AND SPECIFICATIONS, DATED MONTH XX, YEAR, FOR PROJECT NAME IN CITY, STATE, DISTRICT NUMBER XXX IN XXX COUNTY WERE PREPARED UNDER MY SUPERVISION AND, TO THE BEST OF MY KNOWLEDGE, COMPLY WITH THE REQUIREMENTS IDENTIFIED IN 23 ILLINOIS ADMINISTRATIVE CODE, PART 180.

REVIEWED BY LOCAL FIRE DEPARTMENT:  YES  NO

SIGNATURE OF ARCHITECT \_\_\_\_\_

XXXX/XXXX  
DATE

001-XXX  
LICENSE NUMBER (SEAL)

XXXX/XXXX  
EXPIRATION

### SITE LOCATION MAP

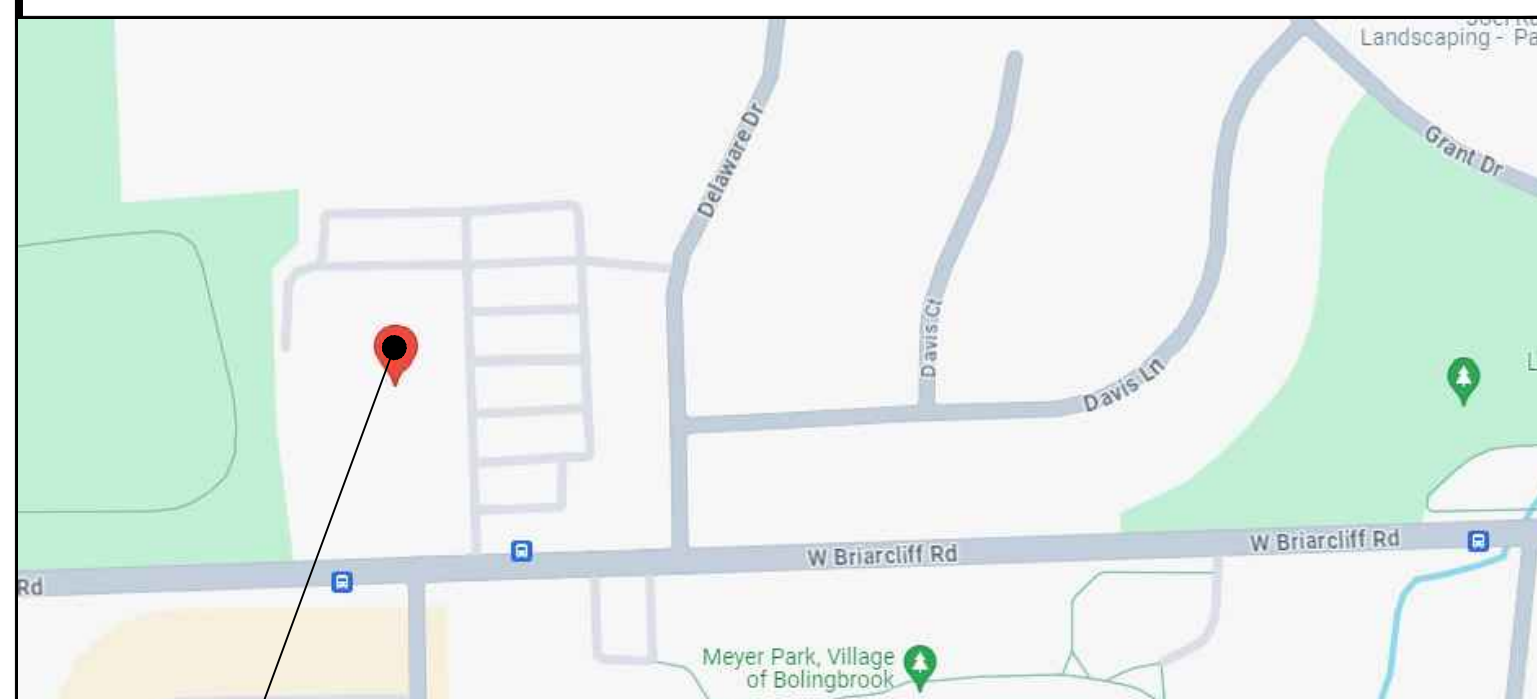

2024 MONUMENT SIGN RENOVATIONS  
AT FOUNTAINDALE PUBLIC LIBRARY  
300 W. BRIARCLIFF RD., BOLINGBROOK, IL 60440

### ISSUED FOR REVIEW:

08/19/2024

TRIA ARCHITECTURE, INC. HEREBY EXPRESSLY RESERVES ALL COPYRIGHT AND OTHER PROPERTY RIGHTS PRESENT WITHIN THESE DOCUMENTS. REPRODUCTION, SALE, OR ALTERATION OF THESE DOCUMENTS IN WHOLE, OR A PORTION THERE OF, SHALL BE PROHIBITED WITHOUT PRIOR WRITTEN CONSENT OF TRIA ARCHITECTURE, INC.

COPYRIGHT 2024  
TRIA ARCHITECTURE, INC.



REVISIONS:
1
2
3
4
5

# T1.00

### EXISTING FLOOR PLAN GENERAL NOTES

- FIELD VERIFY ALL EXISTING CONDITIONS. IN THE EVENT THAT AN ITEM NOT SHOWN ON THE DRAWINGS CONFLICTS WITH WORK UNDER THIS CONTRACT, CONTACT THE ARCHITECT PRIOR TO REMOVAL OF THAT ITEM. ITEMS SHOWN ARE INDICATED TO GIVE A GENERAL SCOPE OF WORK. ANY ITEMS REQUIRING REMOVAL/DEMOLITION TO PROPERLY PERFORM CONTRACT WORK BUT NOT SPECIFICALLY SHOWN, SHALL BE REMOVED BY THE CONTRACTOR AT NO ADDITIONAL COST, PROVIDING THE CONDITION WAS VISIBLE DURING BIDDING.
- SHORE OR BRACE ALL EXISTING CONSTRUCTION AS REQUIRED TO PERFORM WORK.
- EACH CONTRACTOR SHALL BE RESPONSIBLE FOR ALL CORING, CUTTING, PATCHING, INFILLING, REPAIRING, REFINISHING, AND REMOVAL / REPLACEMENT OF BUILDING CONSTRUCTION REQUIRED TO ACCOMMODATE THE INSTALLATION OR REMOVAL OF THEIR WORK. ALL PATCHING, REPAIRING, AND REFINISHING SHALL BE PERFORMED BY THOSE REGULARLY INVOLVED IN THAT TRADE AND SHALL MATCH THE ADJACENT CONSTRUCTION.
- REMOVE ALL EQUIPMENT LOCATED ON OR WITHIN WALL CONSTRUCTION SCHEDULED TO BE REMOVED, SO AS TO NOT DISRUPT EXISTING BUILDING OPERATIONS. DISCONNECT ALL ELECTRICAL WIRING, PULL WIRE BACK TO NEAREST JUNCTION BOX OR TO SERVICE.
- PROTECT ALL EXISTING FINISHES, EQUIPMENT, AND ADJACENT WORK NOT SCHEDULED TO BE REMOVED FROM DAMAGE DURING CONSTRUCTION. ANY DAMAGED FINISHES, EQUIPMENT, OR ADJACENT SURFACES SHALL BE REPAIRED OR REPLACED BY CONTRACTOR AT NO ADDITIONAL COST TO OWNER.
- REFER TO STRUCTURAL, MECHANICAL, ELECTRICAL, PLUMBING, AND FIRE PROTECTION DRAWINGS FOR ADDITIONAL INFORMATION.
- THE OWNER HAS FIRST RIGHT OF REFUSAL FOR ANY MATERIAL, EQUIPMENT OR FIXTURE TO BE REMOVED
- AT ALL EXISTING GRASS AREAS, LANDSCAPING ITEMS OR CONCRETE / ASPHALT SURFACES TO REMAIN - PROTECT DURING CONSTRUCTION AND REPAIR ANY AREAS DAMAGED OR OTHERWISE AFFECTED DURING CONSTRUCTION.
- REMOVE / RELOCATE ALL ACCESSORIES ON WALL CONSTRUCTION TO BE REMOVED.
- GENERAL CONTRACTOR TO COORDINATE ALL ARCHITECTURAL WORK WITH INDICATED STRUCTURAL, MECHANICAL, ELECTRICAL, PLUMBING, AND FIRE PROTECTION WORK - NOTIFY ARCHITECT OF ANY DISCREPANCIES PRIOR TO PERFORMING WORK.
- REMOVE EXISTING MASONRY WALL CONSTRUCTION AS REQUIRED TO INSTALL NEW STRUCTURAL MEMBERS - PATCH, REPAIR, AND PAINT - REFER TO STRUCTURAL DRAWINGS.
- PROVIDE ADDITIONAL WALL AND FLOOR SLAB DEMOLITION AS REQUIRED TO PROVIDE STRUCTURAL, MECHANICAL, ELECTRICAL, PLUMBING, AND FIRE PROTECTION WORK INDICATED.
- ALL ITEMS NOTED TO BE REMOVED SHALL INCLUDE REMOVAL OF ASSOCIATED ADHESIVES, SEALANTS, ANCHORS, HANGERS, AND OTHER ASSOCIATED ACCESSORIES - SURFACE TO BE PREPARED FOR APPLICATION OF FINISH.

**FOUNTAINDALE PUBLIC LIBRARY DISTRICT**  
**2024 MONUMENT SIGN RENOVATIONS AT**  
**FOUNTAINDALE PUBLIC LIBRARY**  
**300 W. BRIARCLIFF RD., BOLINGBROOK, IL 60440**

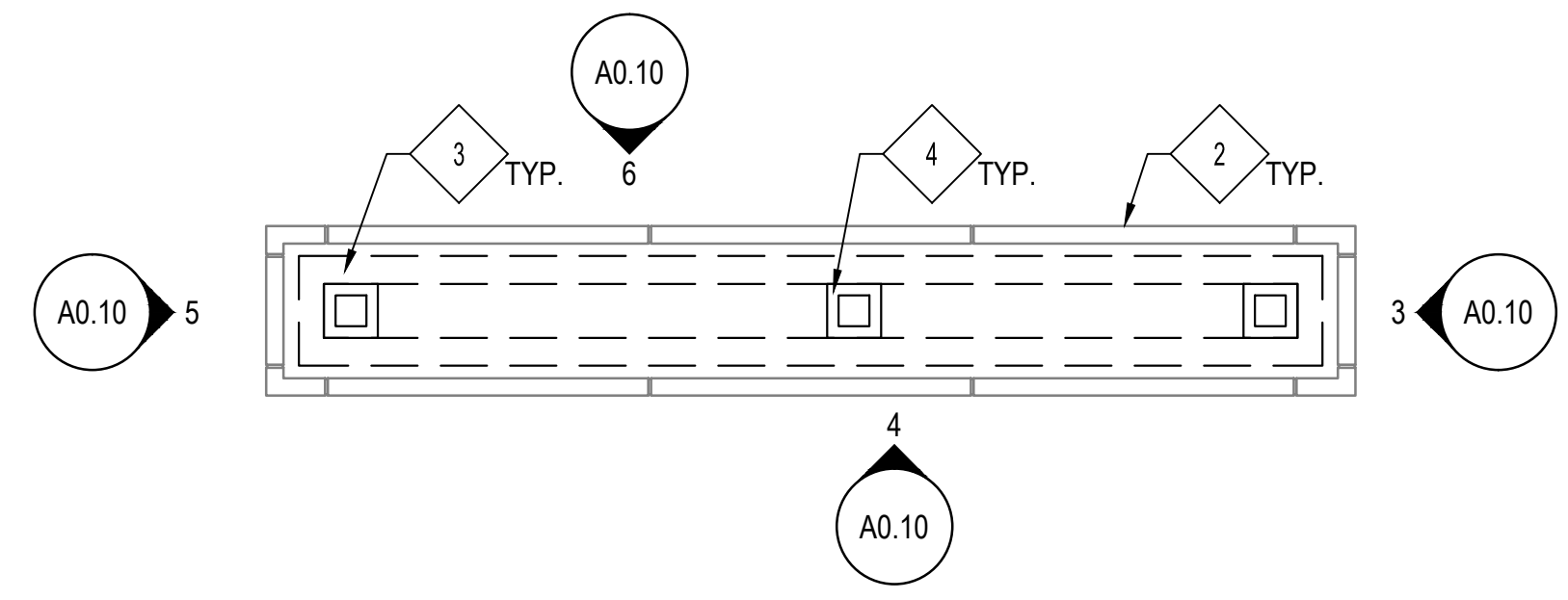

1 EXISTING PLAN  
1/2" = 1'-0"

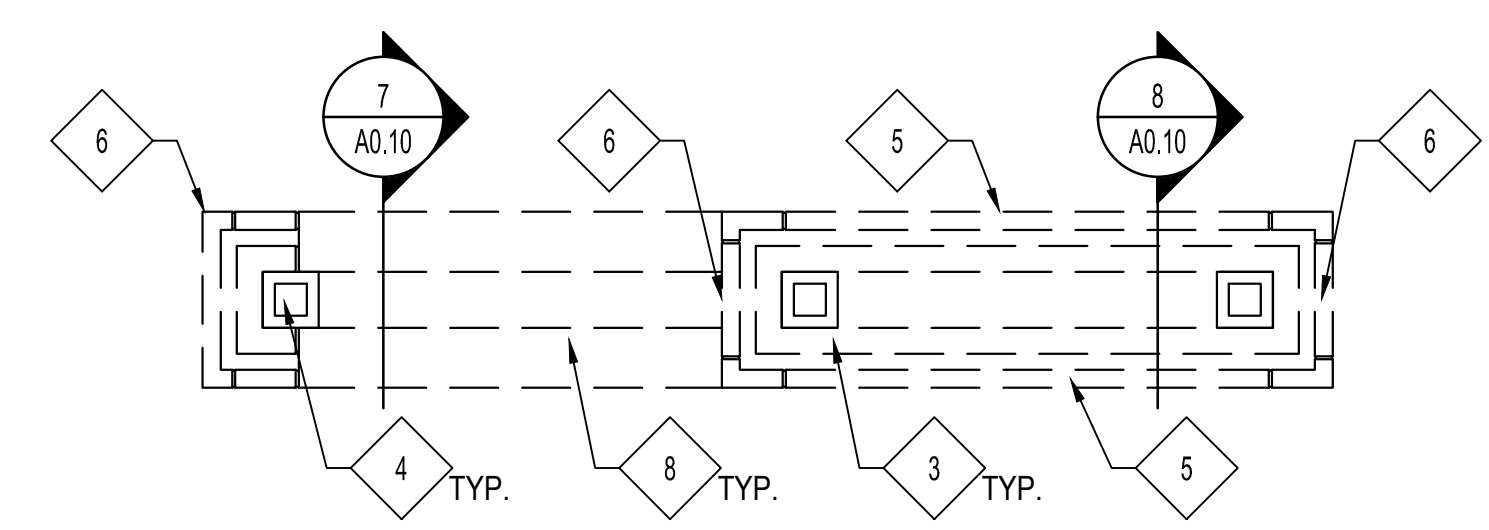

2 EXISTING PLAN  
1/2" = 1'-0"

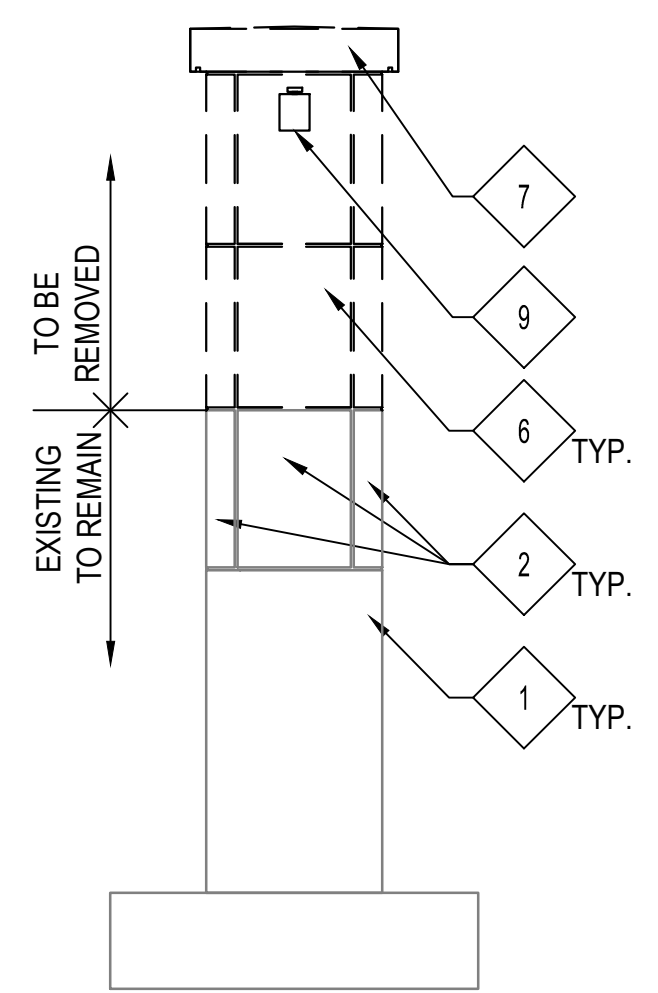

3 EXISTING NORTH ELEVATION  
1/2" = 1'-0"

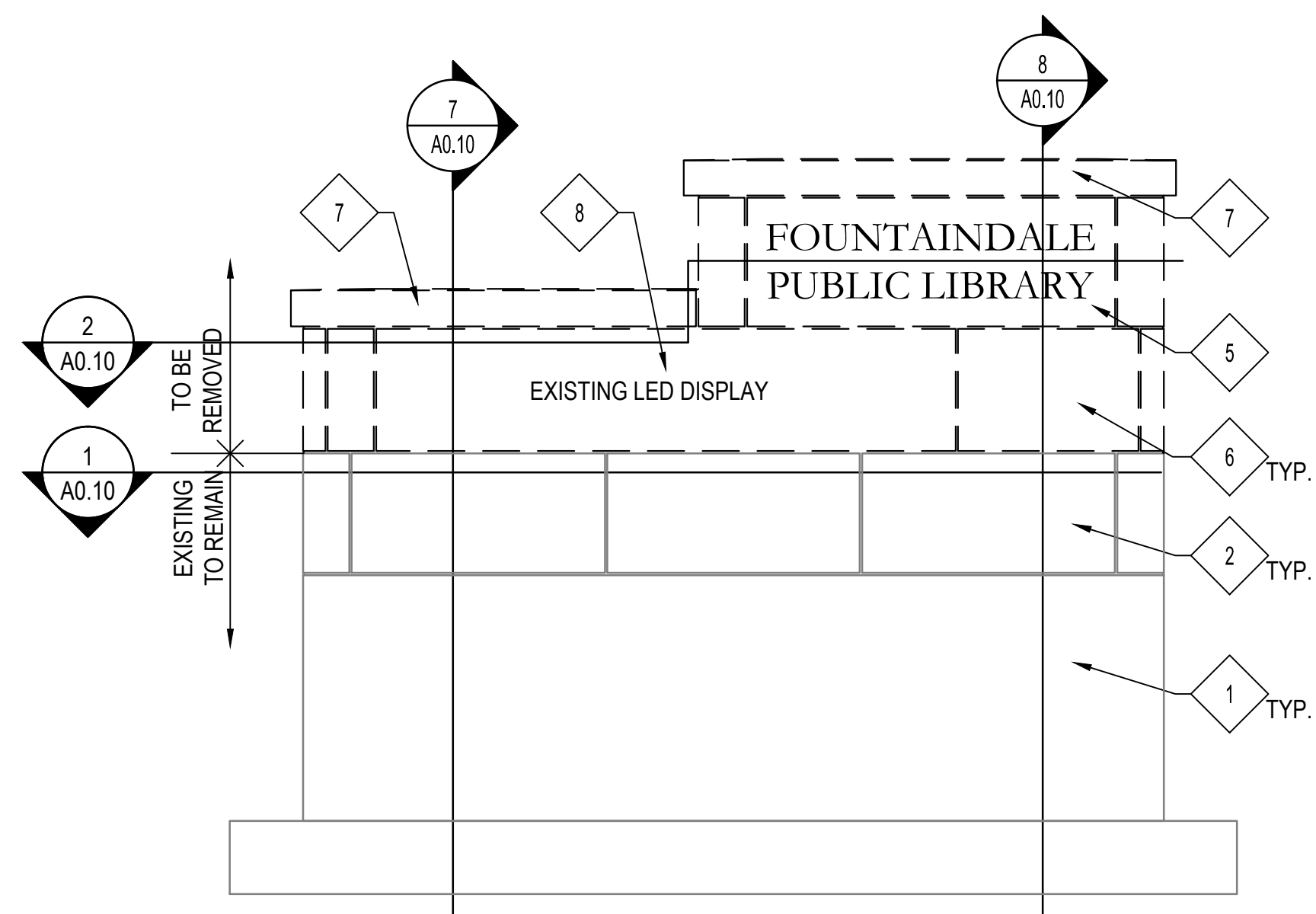

4 EXISTING EAST ELEVATION  
1/2" = 1'-0"

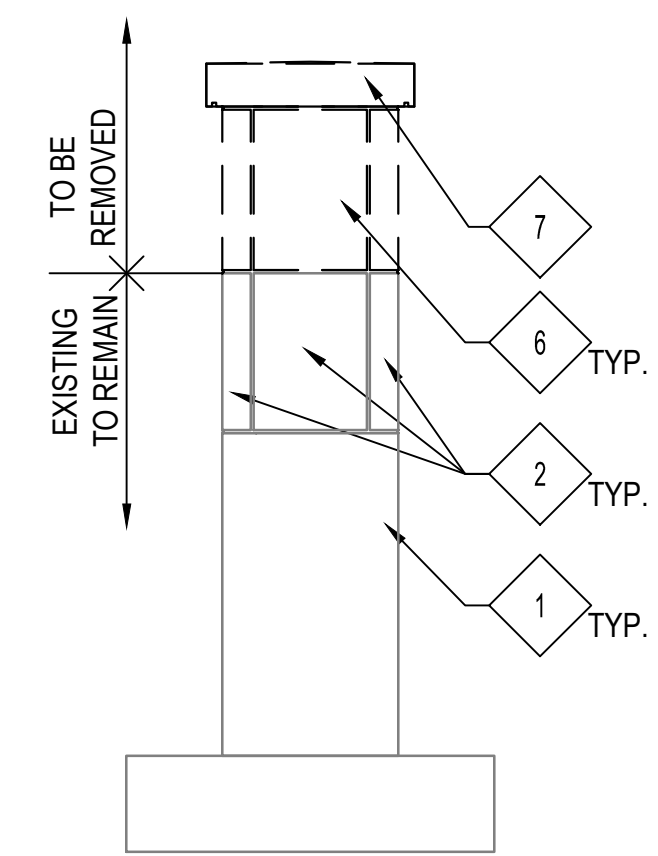

5 EXISTING SOUTH ELEVATION  
1/2" = 1'-0"

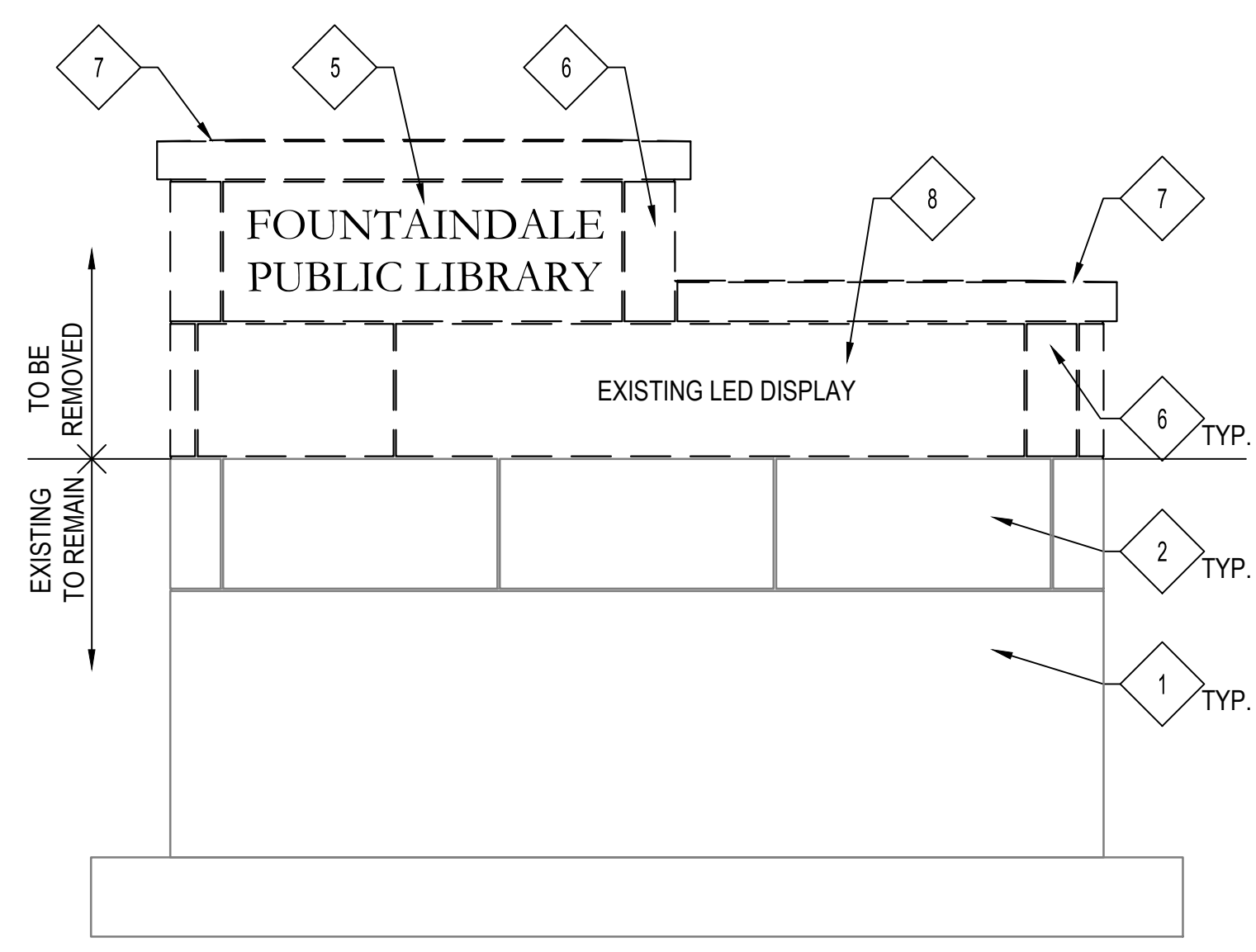

6 EXISTING WEST ELEVATION  
1/2" = 1'-0"

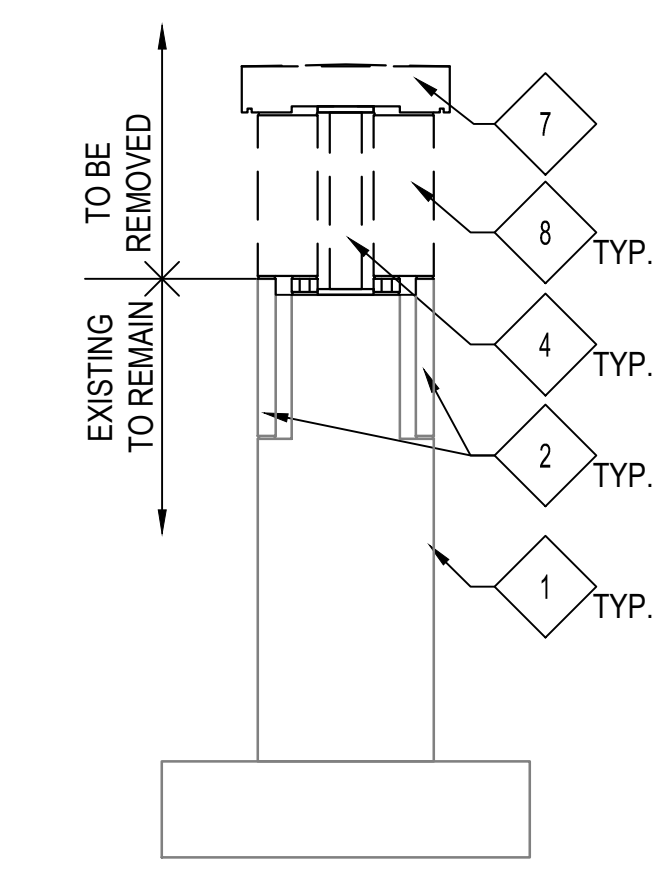

7 EXISTING WALL SECTION  
1/2" = 1'-0"

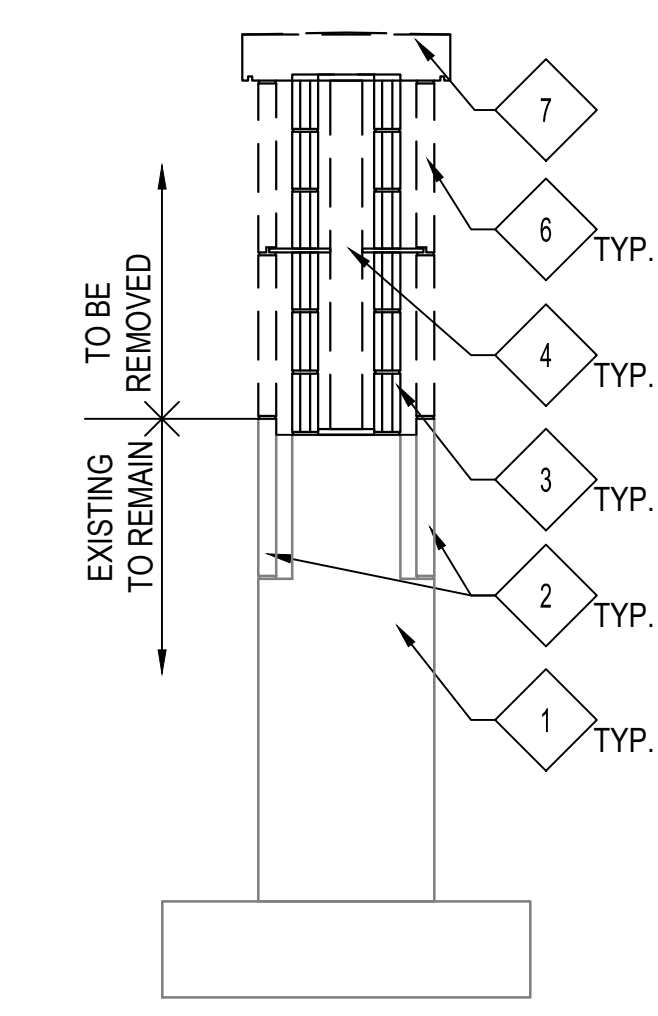

8 EXISTING WALL SECTION  
1/2" = 1'-0"

### EXISTING FLOOR PLAN & ELEVATIONS REFERENCED NOTES

- EXISTING FOUNDATION TO REMAIN.
- EXISTING CAST STONE VENEER TO REMAIN.
- EXISTING WALL CONSTRUCTION TO BE REMOVED.
- EXISTING STRUCTURAL POSTS & FRAME SYSTEM TO BE REMOVED IN THEIR ENTIRETY.
- REMOVE AND SAVE TO REINSTALL THE EXISTING FOUNTAINDALE PUBLIC LIBRARY SIGN STONE.
- EXISTING CAST STONE VENEER TO BE REMOVED.
- EXISTING CAST STONE CAP TO BE REMOVED ENTIRELY.
- EXISTING LED DISPLAY TO BE REMOVED IN ITS ENTIRETY.
- REMOVE AND SAVE EXISTING EXTERIOR LIGHT FIXTURE TO BE REINSTALLED

### LEGEND

- EXISTING CONSTRUCTION TO BE REMOVED.
- EXISTING CONSTRUCTION TO REMAIN.

REVISIONS	
PROJECT NUMBER: 2403B	
PROJECT MANAGER: JO	
DRAWN BY: MM	
ISSUED FOR REVIEW: 09/12/2024	
1	
2	
3	
4	
5	

EXISTING PLANS, ELEVATIONS AND WALL SECTIONS.

### EXISTING FLOOR PLAN GENERAL NOTES

- FIELD VERIFY ALL EXISTING CONDITIONS. IN THE EVENT THAT AN ITEM NOT SHOWN ON THE DRAWINGS CONFLICTS WITH WORK UNDER THIS CONTRACT, CONTACT THE ARCHITECT PRIOR TO REMOVAL OF THAT ITEM. ITEMS SHOWN ARE INDICATED TO GIVE A GENERAL SCOPE OF WORK. ANY ITEMS REQUIRING REMOVAL/DEMOLITION TO PROPERLY PERFORM CONTRACT WORK BUT NOT SPECIFICALLY SHOWN, SHALL BE REMOVED BY THE CONTRACTOR AT NO ADDITIONAL COST, PROVIDING THE CONDITION WAS VISIBLE DURING BIDDING.
- SHORE OR BRACE ALL EXISTING CONSTRUCTION AS REQUIRED TO PERFORM WORK.
- EACH CONTRACTOR SHALL BE RESPONSIBLE FOR ALL CORING, CUTTING, PATCHING, INFILLING, REPAIRING, REFINISHING, AND REMOVAL / REPLACEMENT OF BUILDING CONSTRUCTION REQUIRED TO ACCOMMODATE THE INSTALLATION OR REMOVAL OF THEIR WORK. ALL PATCHING, REPAIRING, AND REFINISHING SHALL BE PERFORMED BY THOSE REGULARLY INVOLVED IN THAT TRADE AND SHALL MATCH THE ADJACENT CONSTRUCTION.
- REMOVE ALL EQUIPMENT LOCATED ON OR WITHIN WALL CONSTRUCTION SCHEDULED TO BE REMOVED, SO AS TO NOT DISRUPT EXISTING BUILDING OPERATIONS. DISCONNECT ALL ELECTRICAL WIRING, PULL WIRE BACK TO NEAREST JUNCTION BOX OR TO SERVICE.
- PROTECT ALL EXISTING FINISHES, EQUIPMENT, AND ADJACENT WORK NOT SCHEDULED TO BE REMOVED FROM DAMAGE DURING CONSTRUCTION. ANY DAMAGED FINISHES, EQUIPMENT, OR ADJACENT SURFACES SHALL BE REPAIRED OR REPLACED BY CONTRACTOR AT NO ADDITIONAL COST TO OWNER.
- REFER TO STRUCTURAL, MECHANICAL, ELECTRICAL, PLUMBING, AND FIRE PROTECTION DRAWINGS FOR ADDITIONAL INFORMATION.
- THE OWNER HAS FIRST RIGHT OF REFUSAL FOR ANY MATERIAL, EQUIPMENT OR FIXTURE TO BE REMOVED
- AT ALL EXISTING GRASS AREAS, LANDSCAPING ITEMS OR CONCRETE / ASPHALT SURFACES TO REMAIN - PROTECT DURING CONSTRUCTION AND REPAIR ANY AREAS DAMAGED OR OTHERWISE AFFECTED DURING CONSTRUCTION.
- REMOVE / RELOCATE ALL ACCESSORIES ON WALL CONSTRUCTION TO BE REMOVED.
- GENERAL CONTRACTOR TO COORDINATE ALL ARCHITECTURAL WORK WITH INDICATED STRUCTURAL, MECHANICAL, ELECTRICAL, PLUMBING, AND FIRE PROTECTION WORK - NOTIFY ARCHITECT OF ANY DISCREPANCIES PRIOR TO PERFORMING WORK.
- REMOVE EXISTING MASONRY WALL CONSTRUCTION AS REQUIRED TO INSTALL NEW STRUCTURAL MEMBERS - PATCH, REPAIR, AND PAINT - REFER TO STRUCTURAL DRAWINGS.
- PROVIDE ADDITIONAL WALL AND FLOOR SLAB DEMOLITION AS REQUIRED TO PROVIDE STRUCTURAL, MECHANICAL, ELECTRICAL, PLUMBING, AND FIRE PROTECTION WORK INDICATED.
- ALL ITEMS NOTED TO BE REMOVED SHALL INCLUDE REMOVAL OF ASSOCIATED ADHESIVES, SEALANTS, HANGERS, AND OTHER ASSOCIATED ACCESSORIES - SURFACE TO BE PREPARED FOR APPLICATION OF FINISH.

**FOUNTAINDALE PUBLIC LIBRARY DISTRICT**  
**2024 MONUMENT SIGN RENOVATIONS AT**  
**FOUNTAINDALE PUBLIC LIBRARY**  
**300 W. BRIARCLIFF RD., BOLINGBROOK, IL 60440**

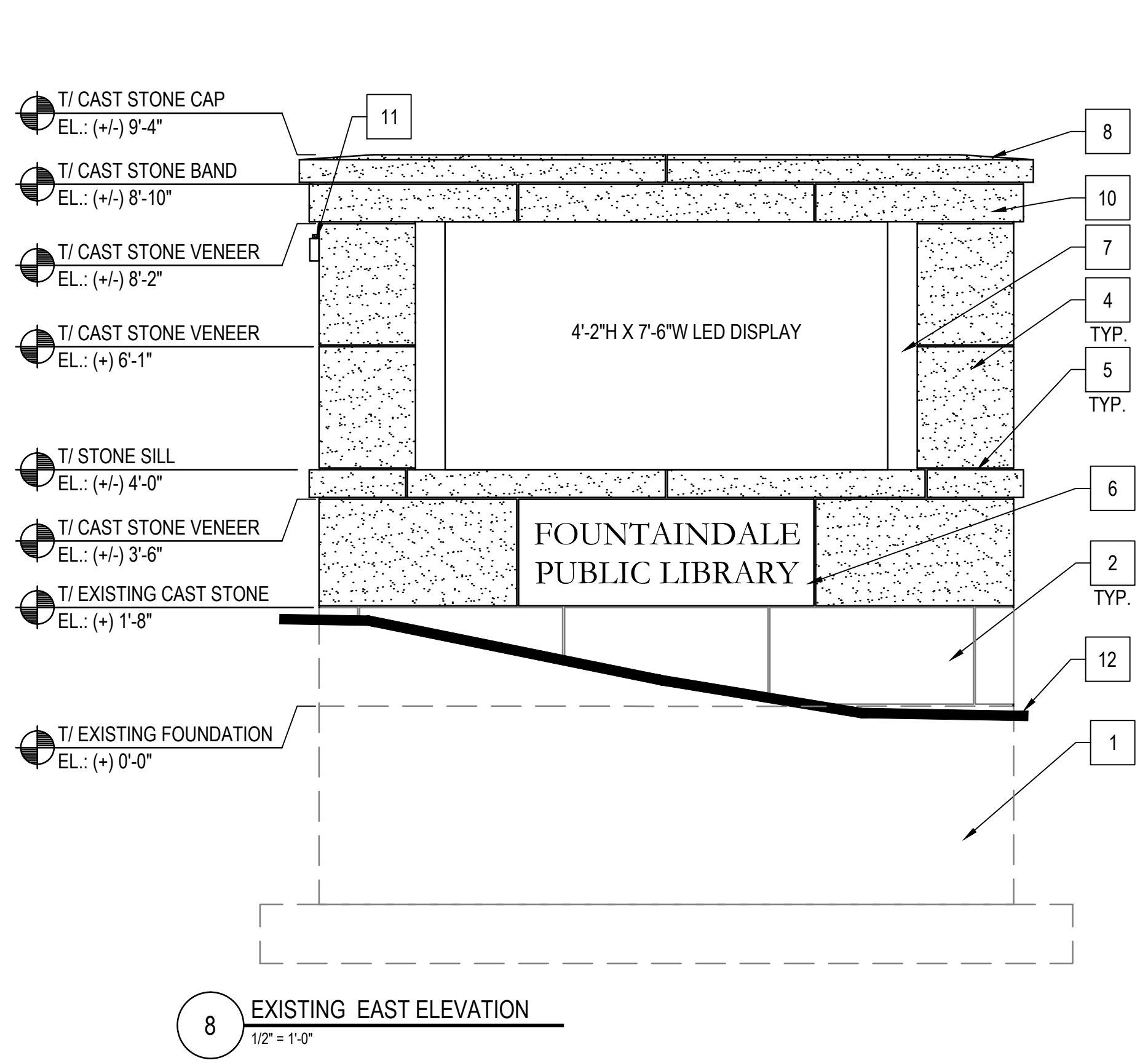
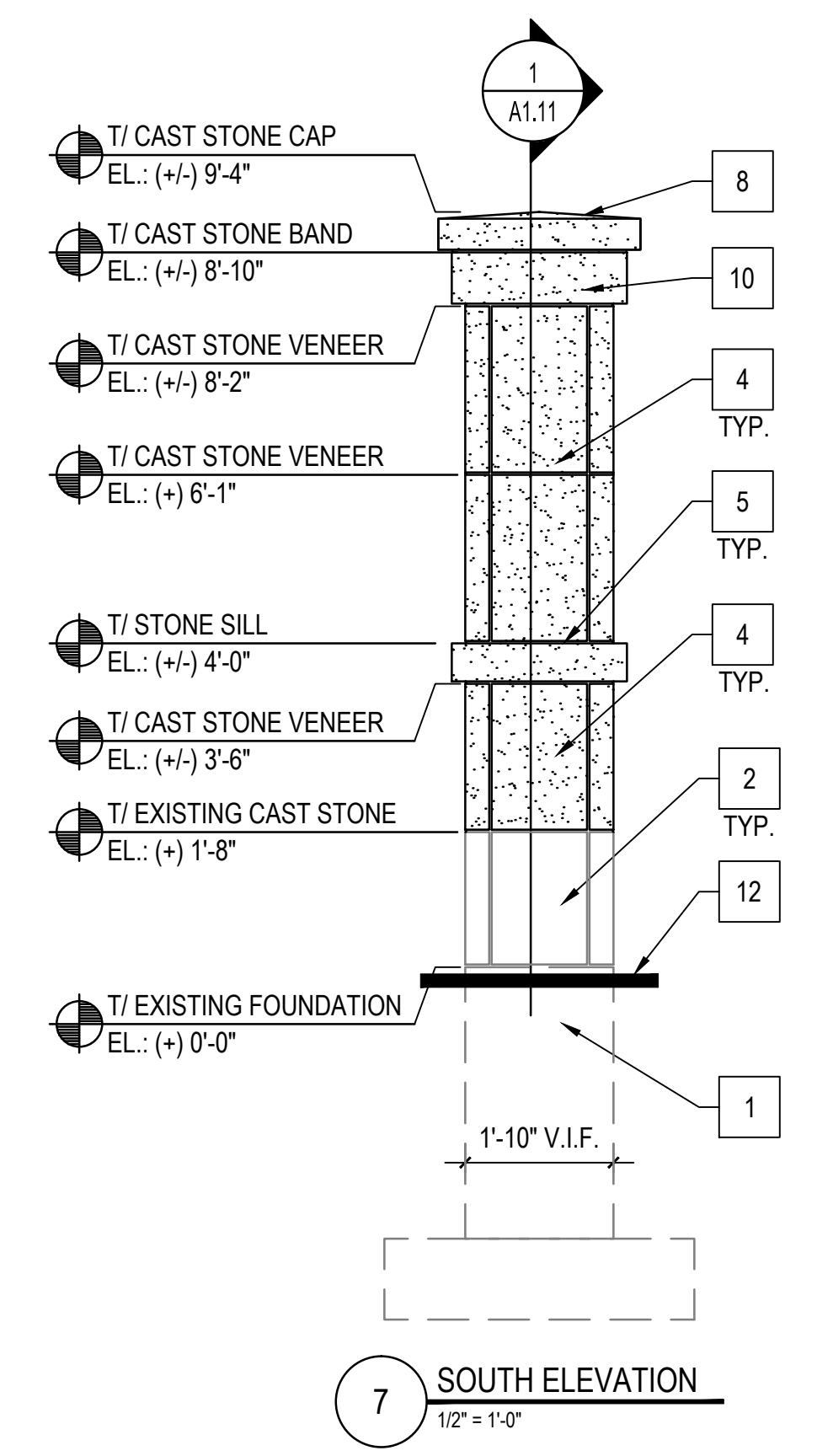
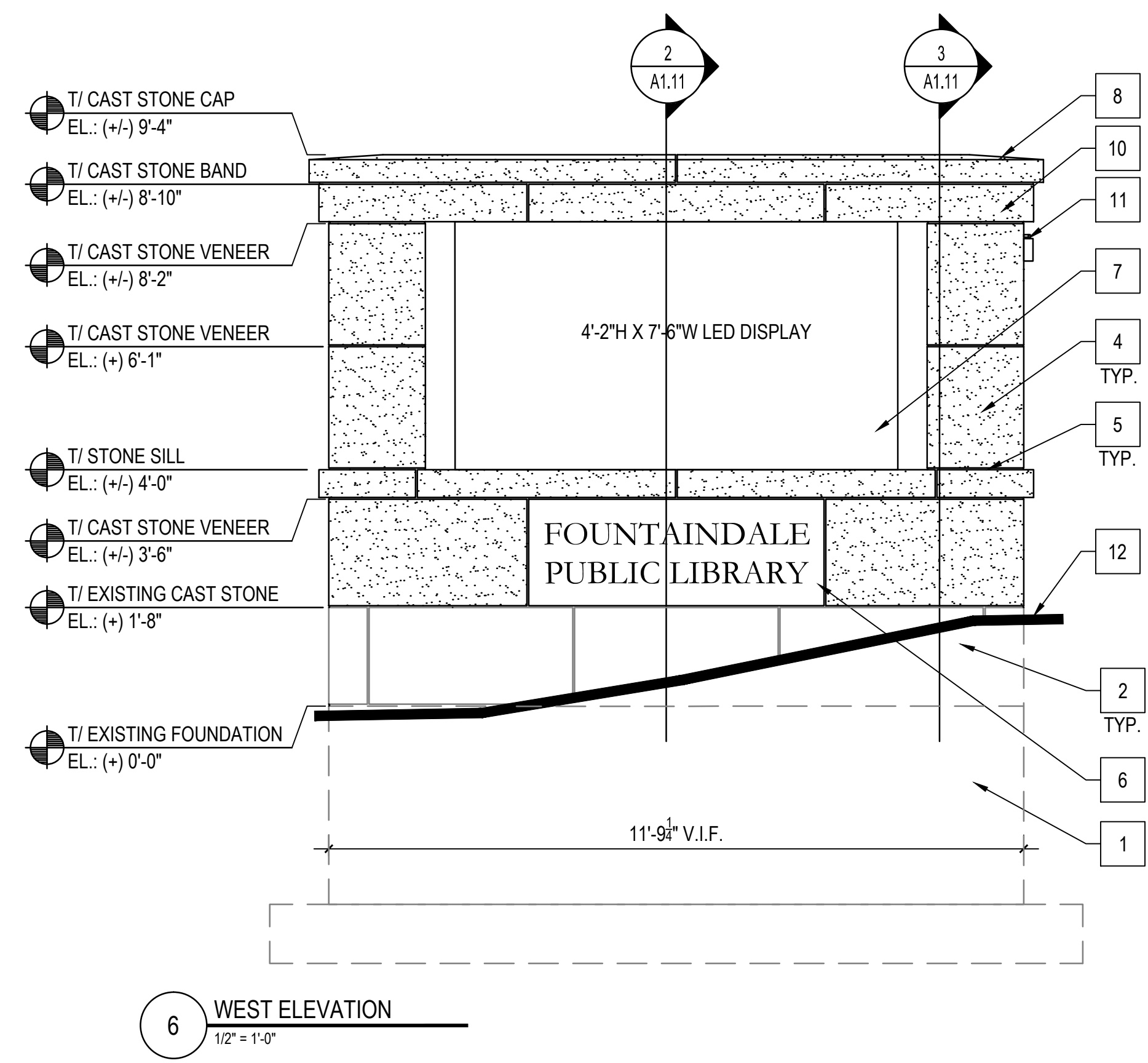
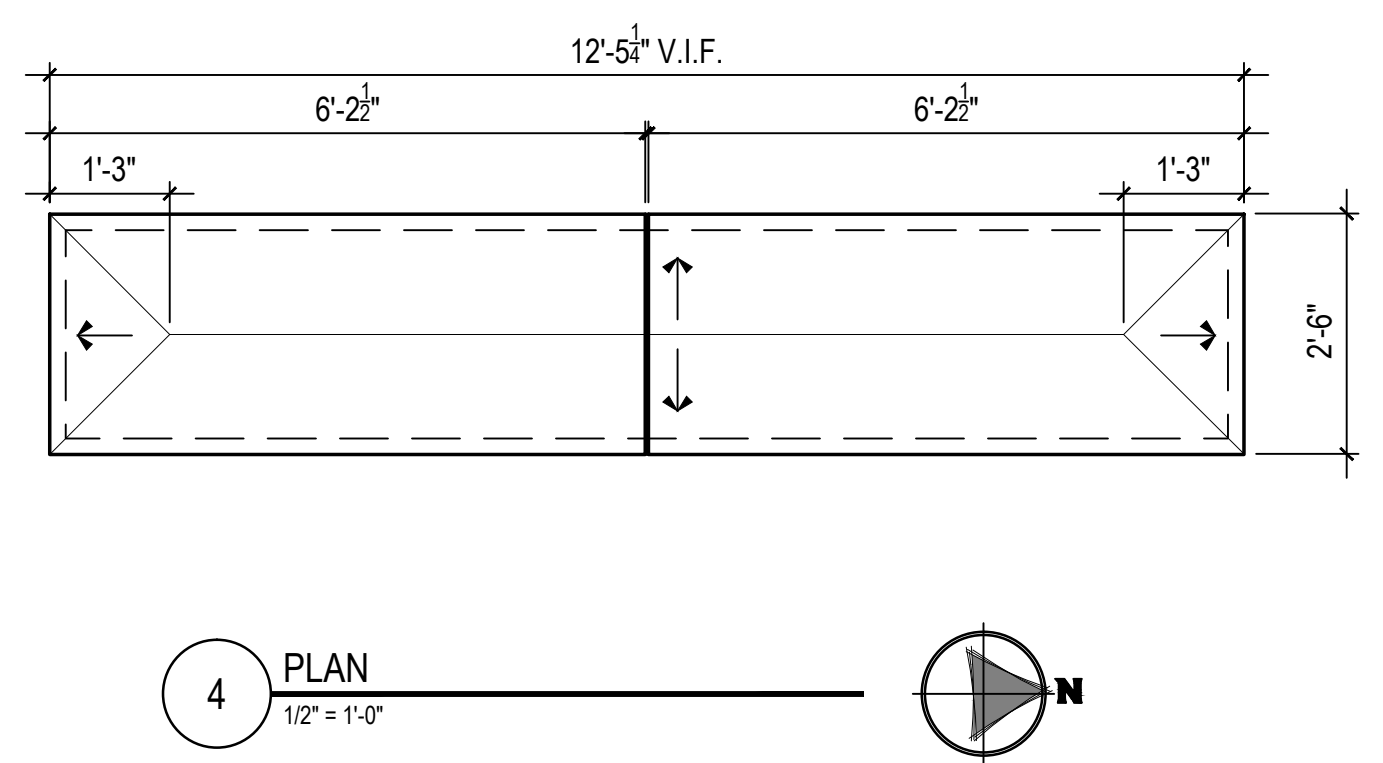
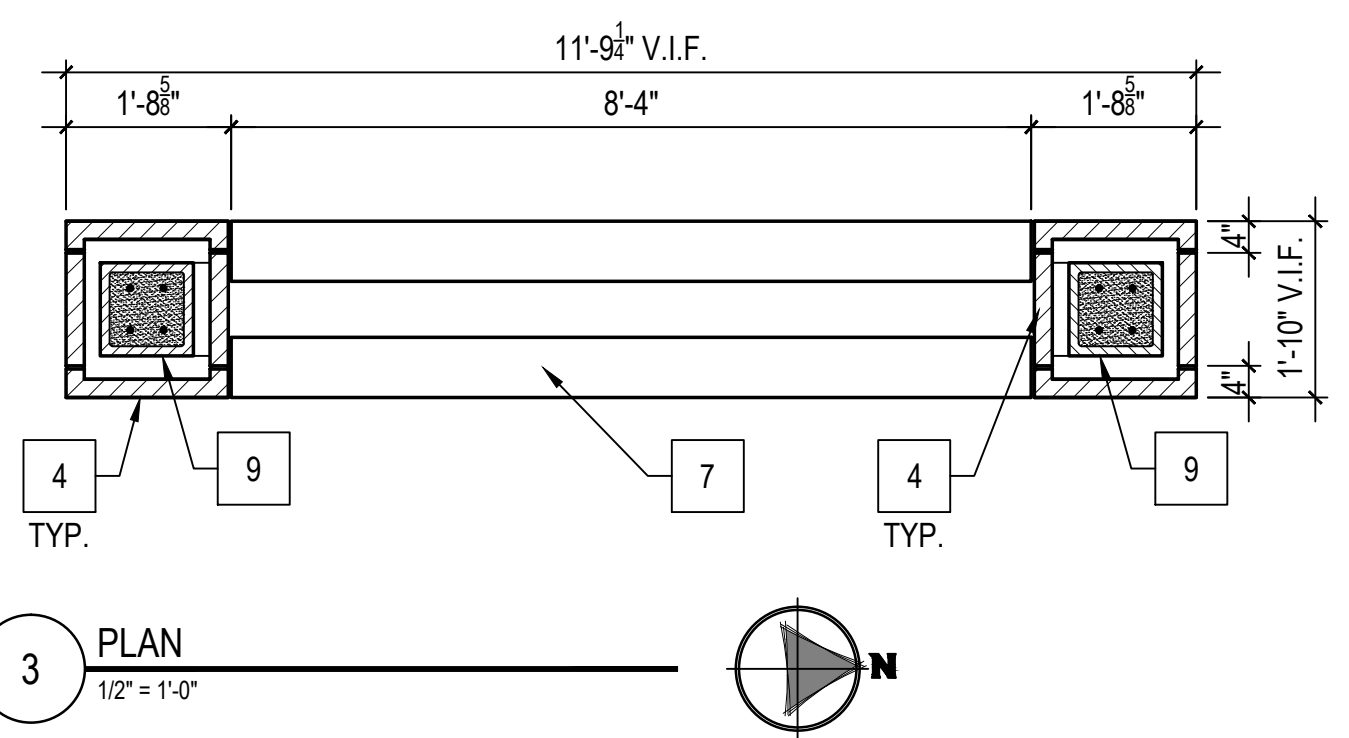
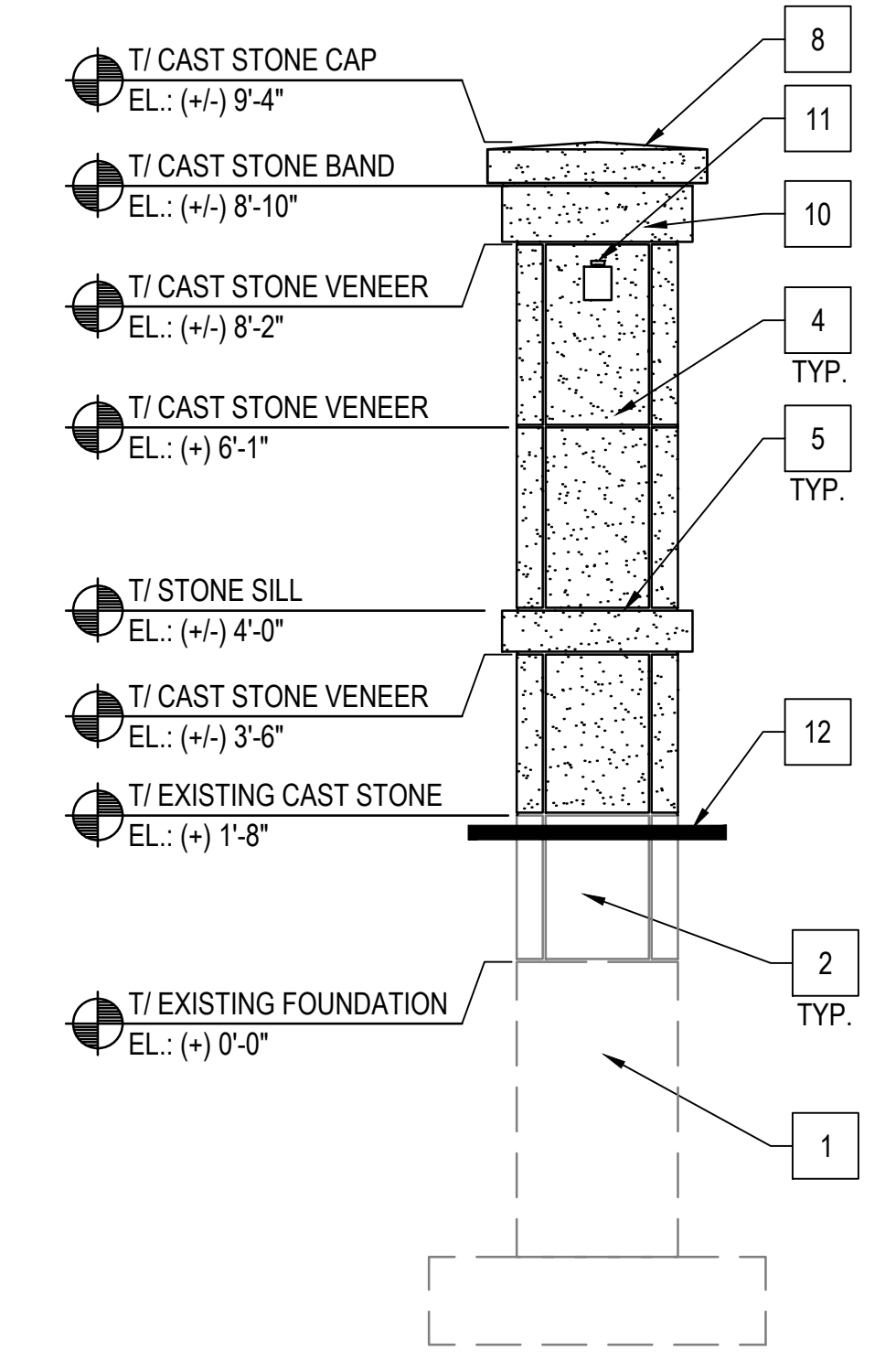
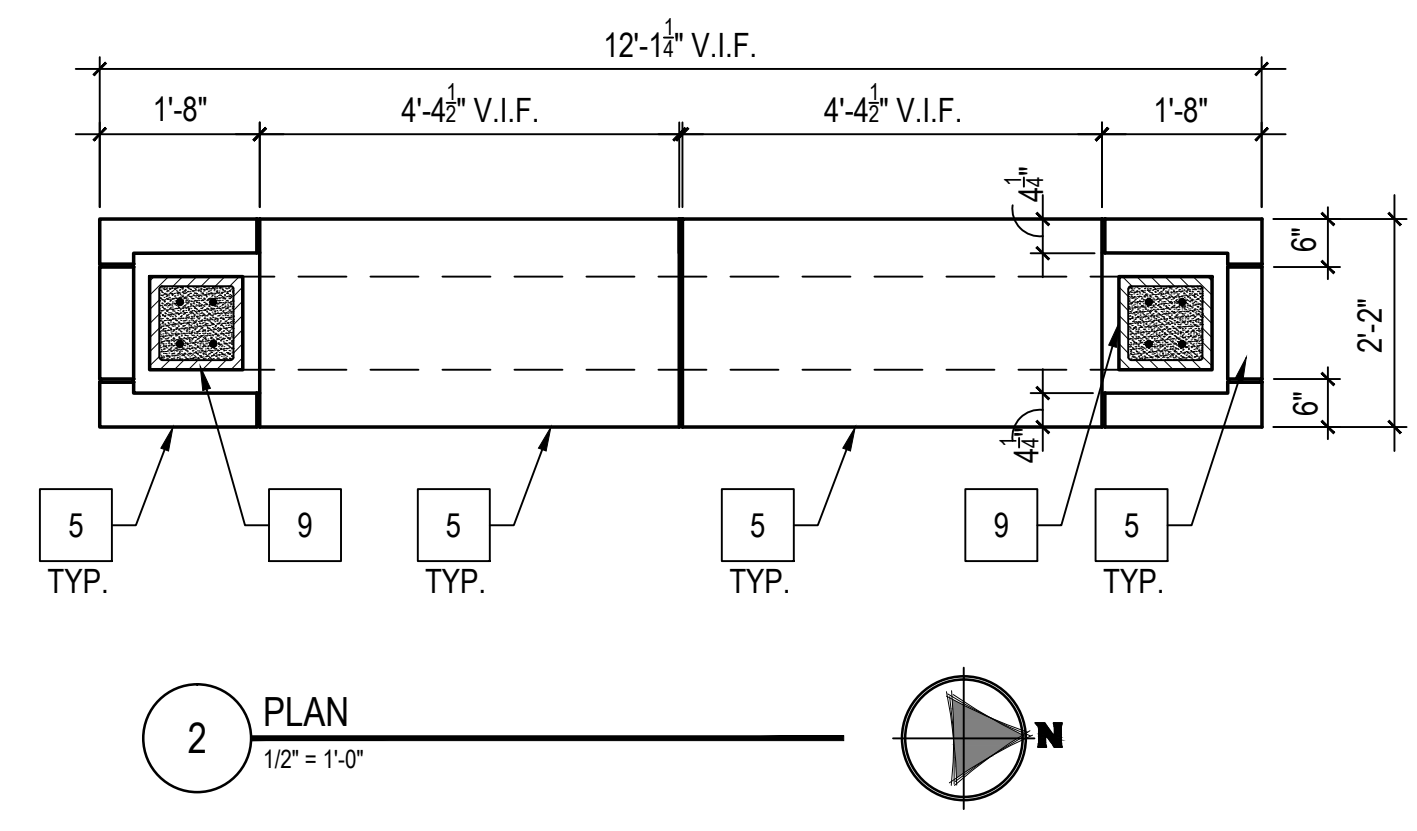
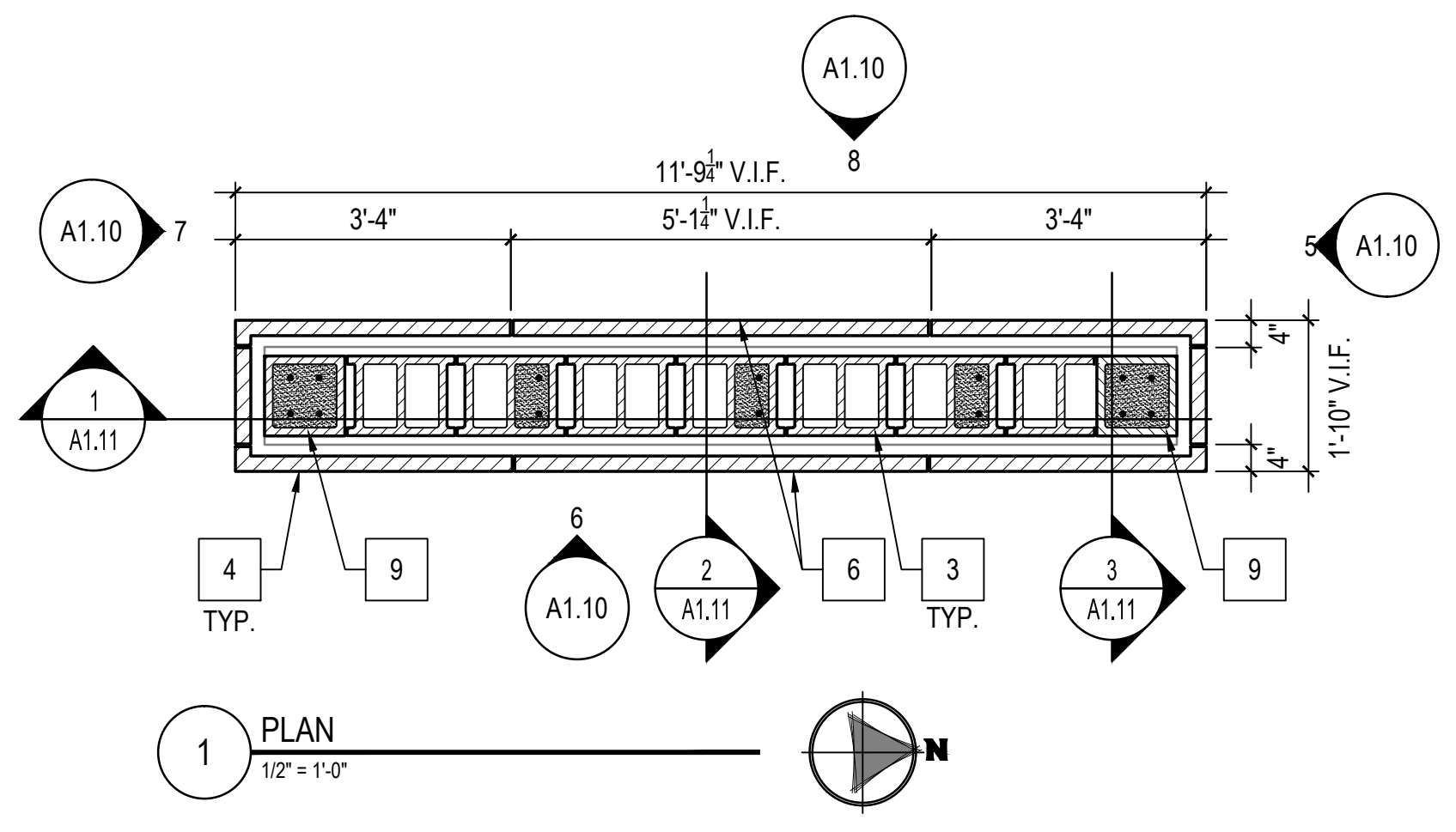

### FLOOR PLAN & ELEVATIONS REFERENCED NOTES

- EXISTING FOUNDATION WALL.
- EXISTING CAST STONE VENEER.
- 12" CONCRETE MASONRY UNIT WALL CONSTRUCTION.
- CAST STONE VENEER MATCHES THE ADJACENT STONE IN THICKNESS, TEXTURE AND COLOR. ALIGN WITH THE EXISTING STONE.
- CAST STONE SILL WITH 5/8" BEVEL EDGE AND INTEGRAL DRIP EDGES. REFER TO DETAIL 6 & 7/A1.11.
- RELOCATED FOUNTAINDALE PUBLIC LIBRARY SIGN STONE.
- PROVIDE AND INSTALL (2) DAKTRONICS LED DISPLAYS - 4'-2" X 7'-6"X7" WITH 10MM MATRIX WITH 108 LINES X 216 COLUMNS AND PROVIDE ALL REQUIRED COMPONENTS FOR WIRELESS CONNECTIVITY - PROVIDE 1 CIRCUIT PER DISPLAY - POWER AS REQUIRED BY MANUFACTURER AND ACCESSORIES FOR A COMPLETE FUNCTIONING SYSTEM - CONTACT SIGNS@EXPSIGNS.COM - COORDINATE WITH OWNER FOR AVAILABLE ELECTRICAL PANEL LOCATION.
- CAST STONE CAP WITH INTEGRAL DRIP EDGES AND 1" MINIMUM SLOPE AT ALL 4 SIDES. REFER TO DETAIL 4 & 5/A1.11.
- 12" X 12" CONCRETE MASONRY UNIT COLUMN. PROVIDE (4) #5 VERTICAL EPOXY COATED REINFORCED BARS GROUTED INTO CONCRETE W/ 8" EMBED.
- 8" CAST STONE BAND WITH INTEGRAL DRIP EDGES. REFER TO DETAIL 4 & 5/A1.11.
- RELOCATED EXTERIOR LIGHT FIXTURE.
- EXISTING GRADE.

### LEGEND

- EXISTING CONSTRUCTION TO REMAIN.
- NEW CONSTRUCTION.

REVISIONS				
NO.	DATE	DESCRIPTION	BY	CHKD.
1				
2				
3				
4				
5				

PROJECT NUMBER: 24038  
 PROJECT MANAGER: JG  
 DRAWN BY: MM  
 ISSUED FOR REVIEW: 09/12/2024  
 PLAN DETAILS AND ELEVATIONS

PROJECT NUMBER: 24038	REVISIONS:
PROJECT MANAGER: JG	1
DRAWN BY: MM	2
ISSUED FOR REVIEW:	3
09/12/2024	4
	5
SECTIONS AND DETAILS	

### EXISTING FLOOR PLAN GENERAL NOTES

- FIELD VERIFY ALL EXISTING CONDITIONS. IN THE EVENT THAT AN ITEM NOT SHOWN ON THE DRAWINGS CONFLICTS WITH WORK UNDER THIS CONTRACT, CONTACT THE ARCHITECT PRIOR TO REMOVAL OF THAT ITEM. ITEMS SHOWN ARE INDICATED TO GIVE A GENERAL SCOPE OF WORK. ANY ITEMS REQUIRING REMOVAL/DEMOLITION TO PROPERLY PERFORM CONTRACT WORK BUT NOT SPECIFICALLY SHOWN, SHALL BE REMOVED BY THE CONTRACTOR AT NO ADDITIONAL COST, PROVIDING THE CONDITION WAS VISIBLE DURING BIDDING.
- SHORE OR BRACE ALL EXISTING CONSTRUCTION AS REQUIRED TO PERFORM WORK.
- EACH CONTRACTOR SHALL BE RESPONSIBLE FOR ALL CORING, CUTTING, PATCHING, INFILLING, REPAIRING, REFINISHING, AND REMOVAL / REPLACEMENT OF BUILDING CONSTRUCTION REQUIRED TO ACCOMMODATE THE INSTALLATION OR REMOVAL OF THEIR WORK. ALL PATCHING, REPAIRING, AND REFINISHING SHALL BE PERFORMED BY THOSE REGULARLY INVOLVED IN THAT TRADE AND SHALL MATCH THE ADJACENT CONSTRUCTION.
- REMOVE ALL EQUIPMENT LOCATED ON OR WITHIN WALL CONSTRUCTION SCHEDULED TO BE REMOVED, SO AS TO NOT DISRUPT EXISTING BUILDING OPERATIONS. DISCONNECT ALL ELECTRICAL WIRING, PULL WIRE BACK TO NEAREST JUNCTION BOX OR TO SERVICE.
- PROTECT ALL EXISTING FINISHES, EQUIPMENT, AND ADJACENT WORK NOT SCHEDULED TO BE REMOVED FROM DAMAGE DURING CONSTRUCTION. ANY DAMAGED FINISHES, EQUIPMENT, OR ADJACENT SURFACES SHALL BE REPAIRED OR REPLACED BY CONTRACTOR AT NO ADDITIONAL COST TO OWNER.
- REFER TO STRUCTURAL, MECHANICAL, ELECTRICAL, PLUMBING, AND FIRE PROTECTION DRAWINGS FOR ADDITIONAL INFORMATION.
- THE OWNER HAS FIRST RIGHT OF REFUSAL FOR ANY MATERIAL, EQUIPMENT OR FIXTURE TO BE REMOVED
- AT ALL EXISTING GRASS AREAS, LANDSCAPING ITEMS OR CONCRETE / ASPHALT SURFACES TO REMAIN - PROTECT DURING CONSTRUCTION AND REPAIR ANY AREAS DAMAGED OR OTHERWISE AFFECTED DURING CONSTRUCTION.
- REMOVE / RELOCATE ALL ACCESSORIES ON WALL CONSTRUCTION TO BE REMOVED.
- GENERAL CONTRACTOR TO COORDINATE ALL ARCHITECTURAL WORK WITH INDICATED STRUCTURAL, MECHANICAL, ELECTRICAL, PLUMBING, AND FIRE PROTECTION WORK - NOTIFY ARCHITECT OF ANY DISCREPANCIES PRIOR TO PERFORMING WORK.
- REMOVE EXISTING MASONRY WALL CONSTRUCTION AS REQUIRED TO INSTALL NEW STRUCTURAL MEMBERS - PATCH, REPAIR, AND PAINT - REFER TO STRUCTURAL DRAWINGS.
- PROVIDE ADDITIONAL WALL AND FLOOR SLAB DEMOLITION AS REQUIRED TO PROVIDE STRUCTURAL, MECHANICAL, ELECTRICAL, PLUMBING, AND FIRE PROTECTION WORK INDICATED.
- ALL ITEMS NOTED TO BE REMOVED SHALL INCLUDE REMOVAL OF ASSOCIATED ADHESIVES, SEALANTS, ANCHORS, HANGERS, AND OTHER ASSOCIATED ACCESSORIES - SURFACE TO BE PREPARED FOR APPLICATION OF FINISH.

### FLOOR PLAN & ELEVATIONS REFERENCED NOTES

- EXISTING FOUNDATION WALL.
- EXISTING CAST STONE VENEER.
- 12" CONCRETE MASONRY UNIT WALL CONSTRUCTION.
- CAST STONE VENEER MATCHES THE ADJACENT STONE IN THICKNESS, TEXTURE AND COLOR. ALIGN WITH THE EXISTING STONE.
- CAST STONE SILL WITH 5/8" BEVEL EDGE AND INTEGRAL DRIP EDGES. REFER TO DETAIL 6 & 7/A1.11.
- RELOCATED FOUNTAINDALE PUBLIC LIBRARY SIGN STONE.
- PROVIDE AND INSTALL (2) DAKTRONICS LED DISPLAYS - 4'-2" X 7'-6" X 7" WITH 10MM MATRIX WITH 108 LINES X 216 COLUMNS AND PROVIDE ALL REQUIRED COMPONENTS FOR WIRELESS CONNECTIVITY - PROVIDE 1 CIRCUIT PER DISPLAY - POWER AS REQUIRED BY MANUFACTURER AND ACCESSORIES FOR A COMPLETE FUNCTIONING SYSTEM - CONTACT SIGNS@EXPSIGNS.COM - COORDINATE WITH OWNER FOR AVAILABLE ELECTRICAL PANEL LOCATION.
- CAST STONE CAP WITH INTEGRAL DRIP EDGES AND 1" MINIMUM SLOPE AT ALL 4 SIDES. REFER TO DETAIL 4 & 5/A1.11.
- 12" X 12" CONCRETE MASONRY UNIT COLUMN. PROVIDE (4) #5 VERTICAL EPOXY COATED REINFORCED BARS GROUTED INTO CONCRETE W/ 8" EMBED.
- 8" CAST STONE BAND WITH INTEGRAL DRIP EDGES. REFER TO DETAIL 4 & 5/A1.11.
- #5 EPOXY COATED REINFORCED BARS GROUTED INTO CONCRETE W/ 8" EMBED AT 32" ON CENTER VERTICALLY.

### LEGEND

- EXISTING CONSTRUCTION TO REMAIN.
- NEW CONSTRUCTION.

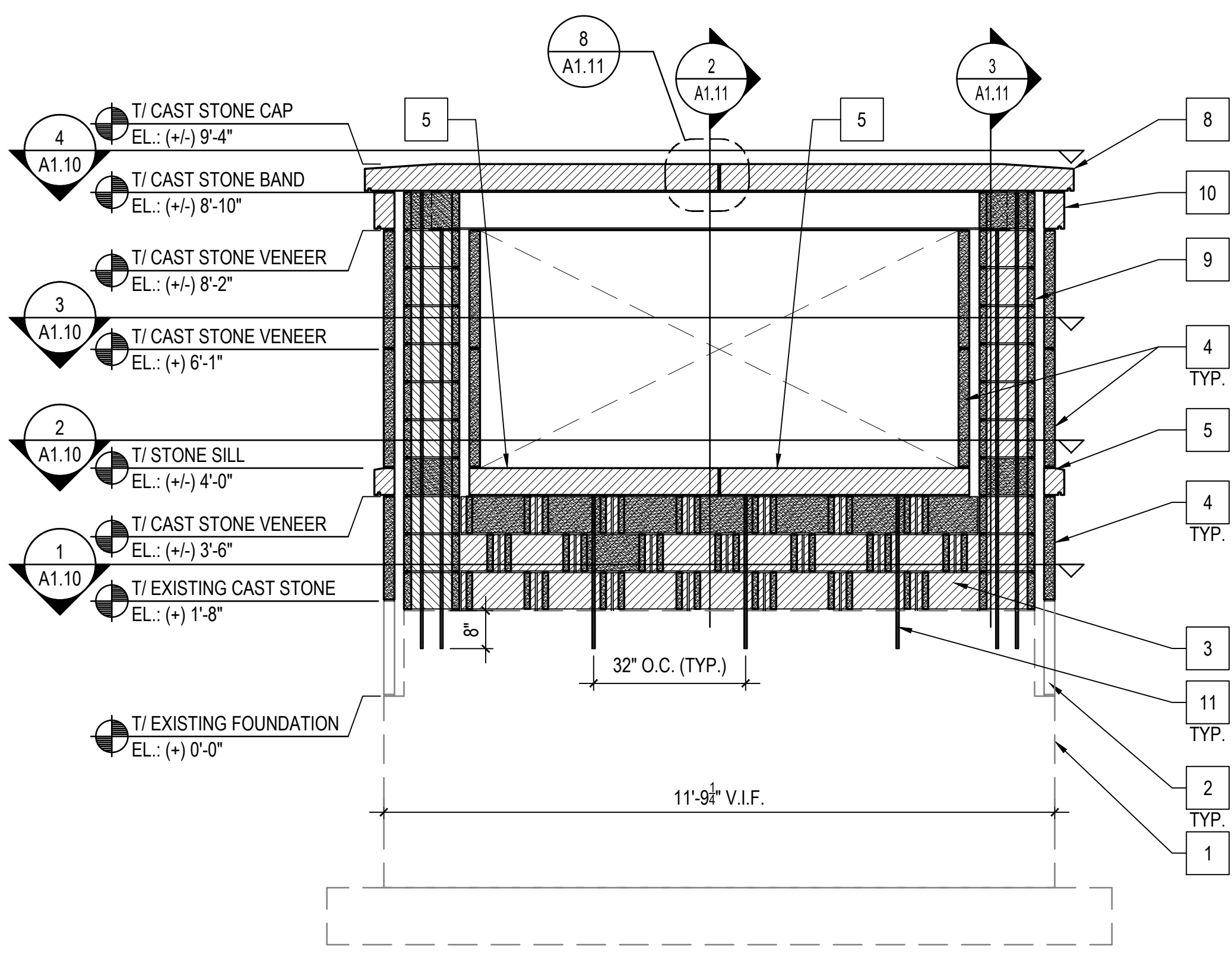

**1 SECTION**  
1/2" = 1'-0"

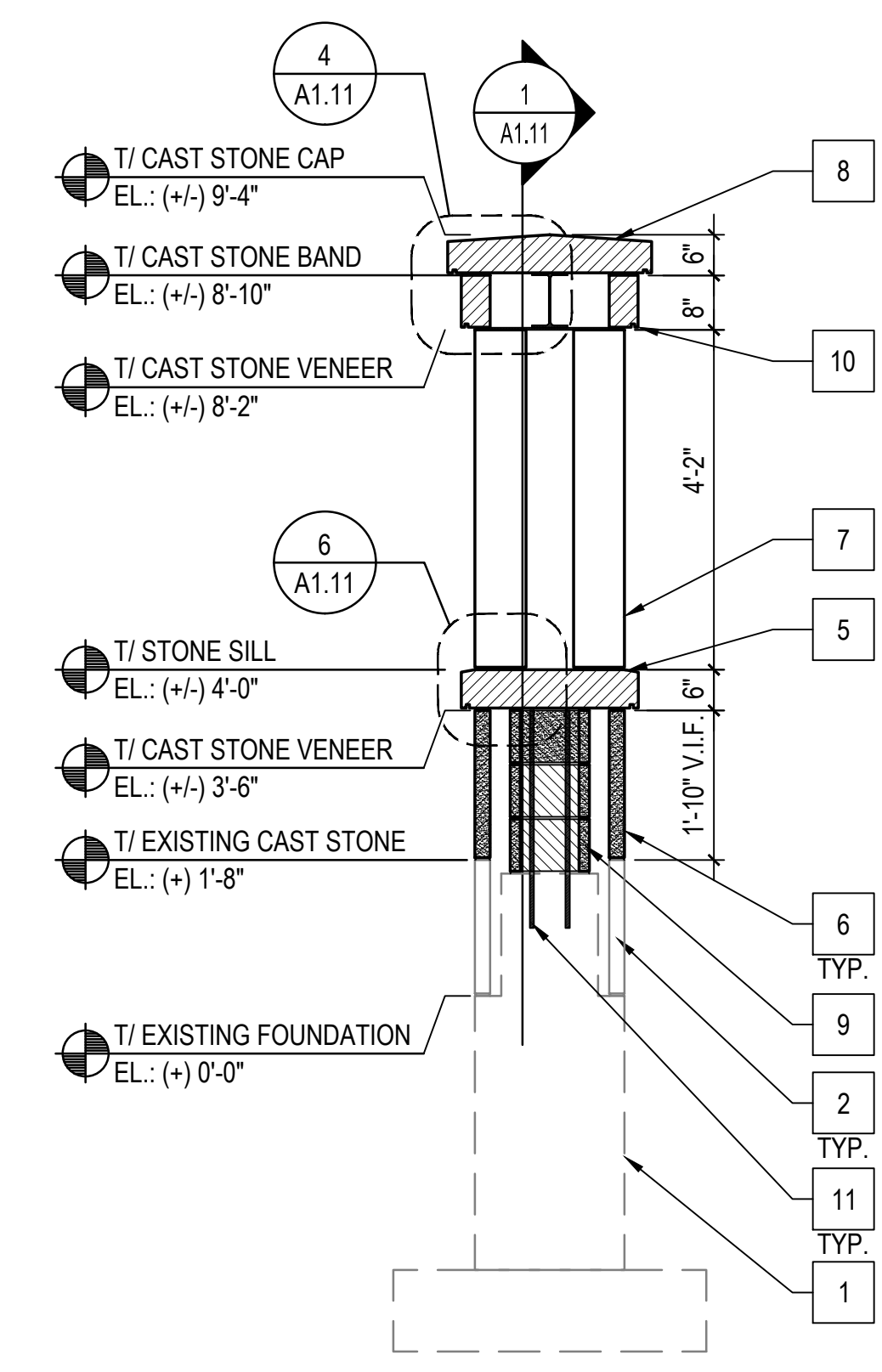

**2 SECTION**  
1/2" = 1'-0"

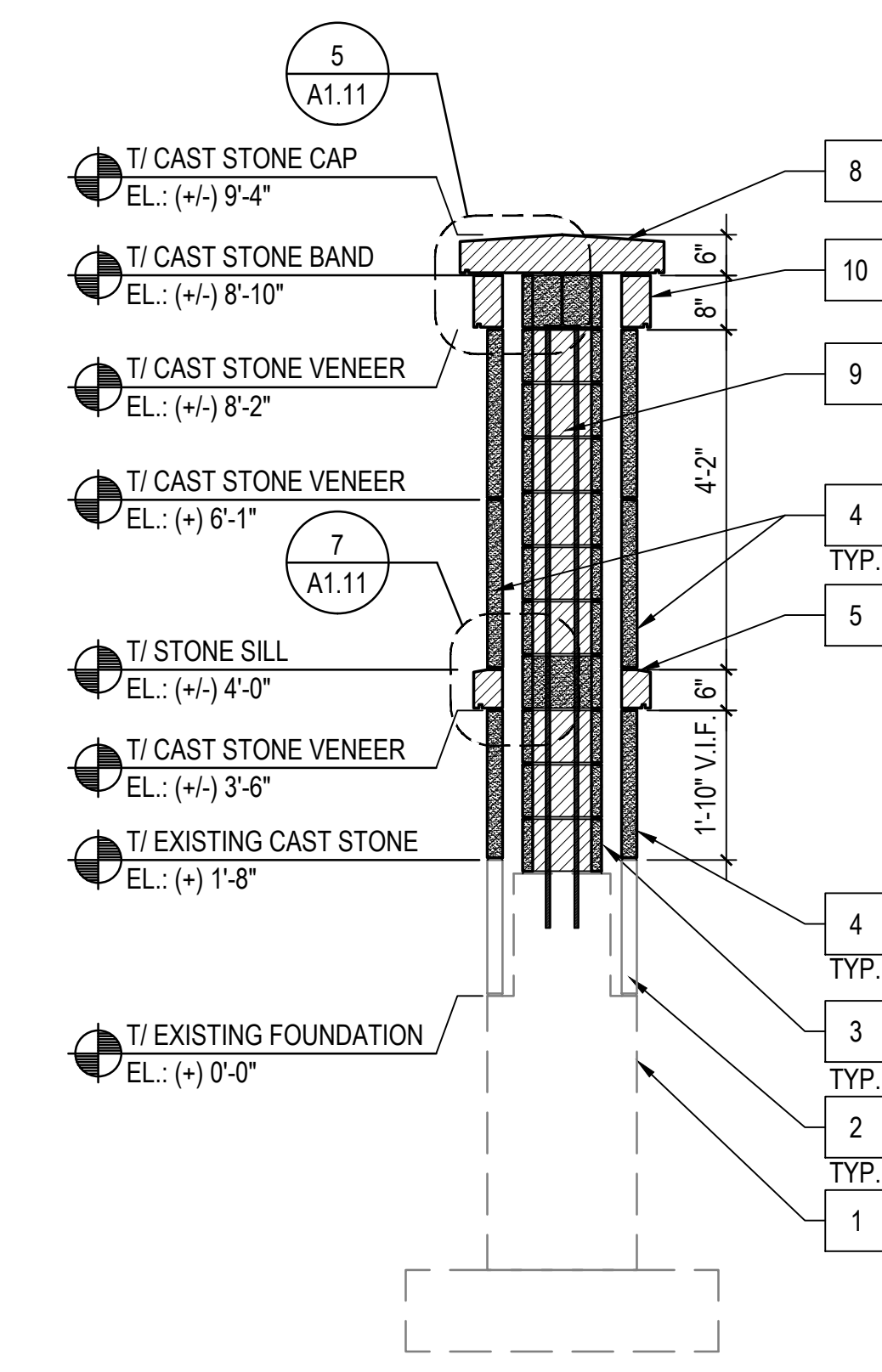

**3 SECTION**  
1/2" = 1'-0"

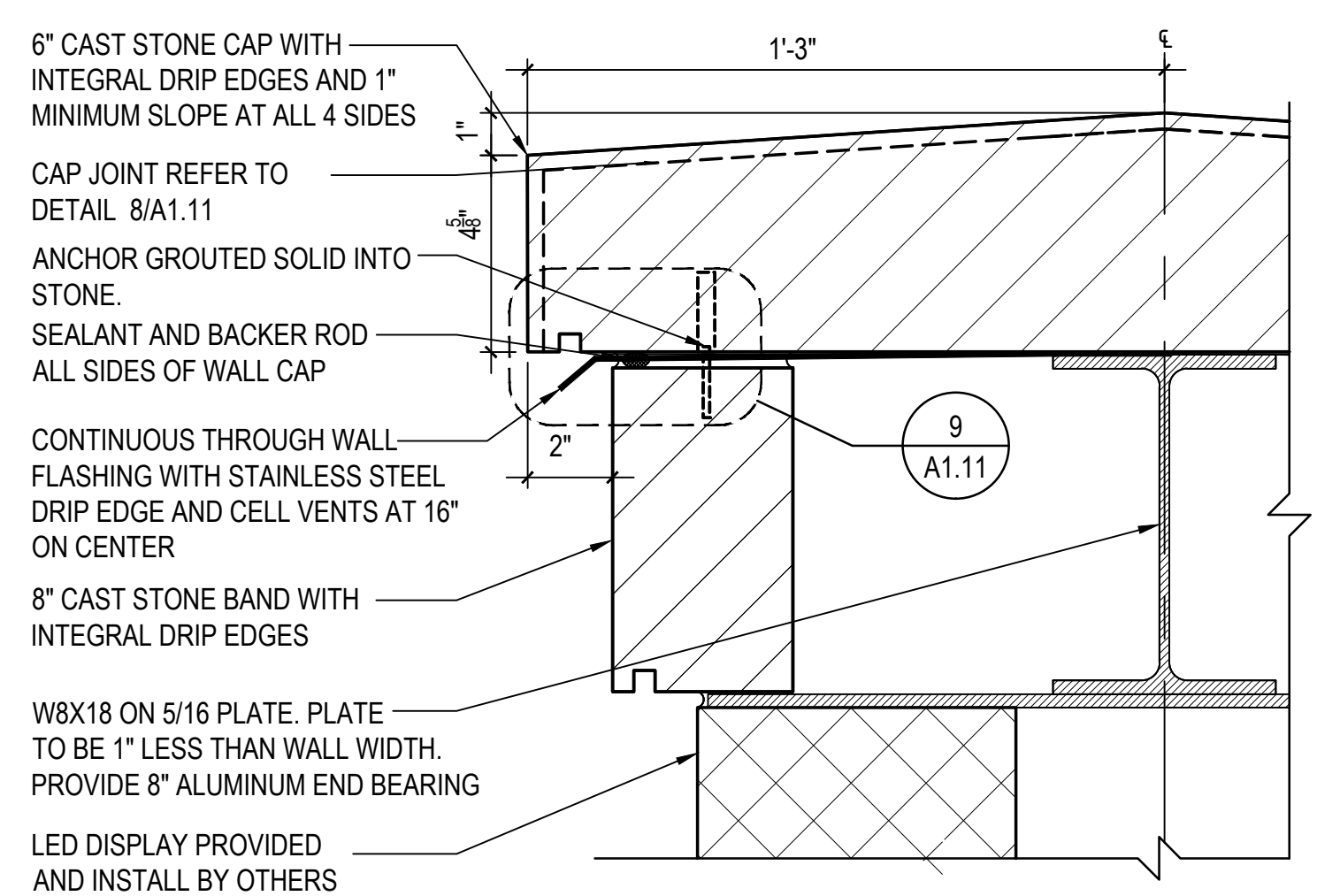

**4 CAP STONE DETAIL**  
1/2" = 1'-0"

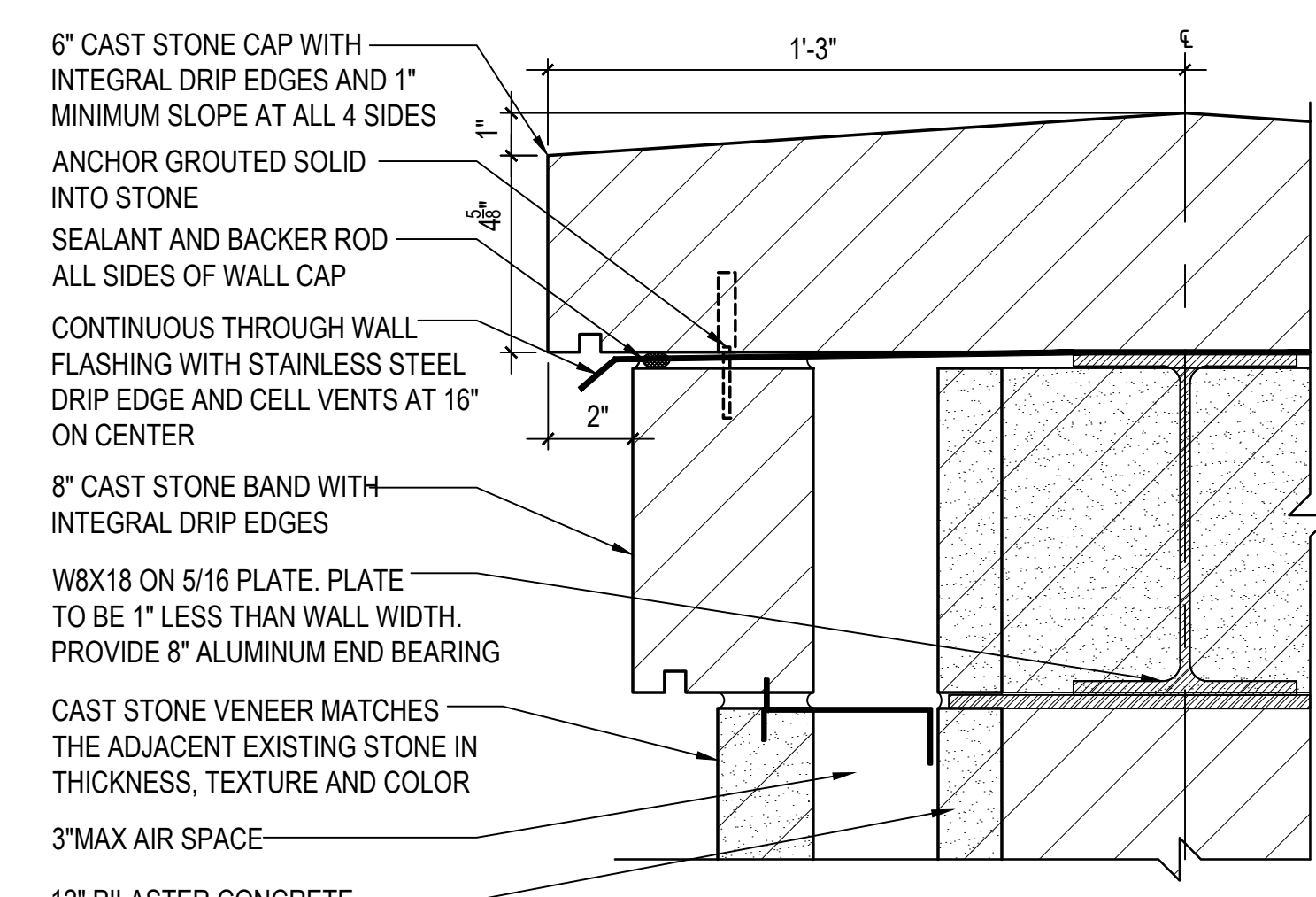

**5 CAP STONE DETAIL**  
1/2" = 1'-0"

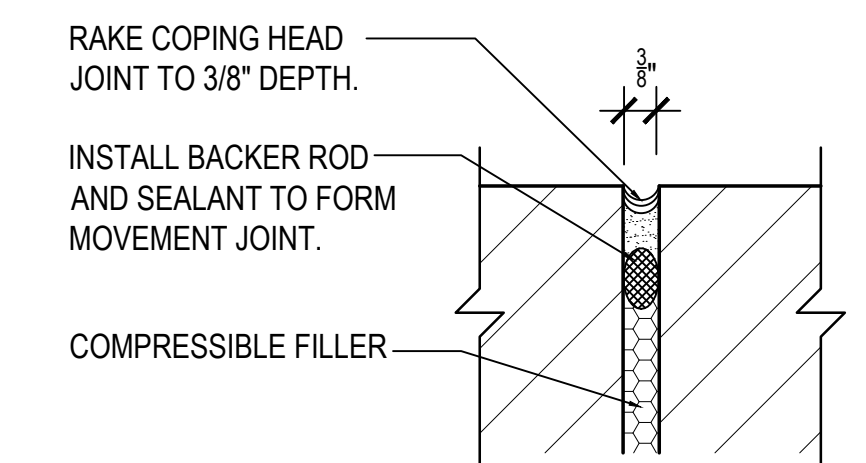

**8 JOIN DETAIL**  
6" = 1'-0"

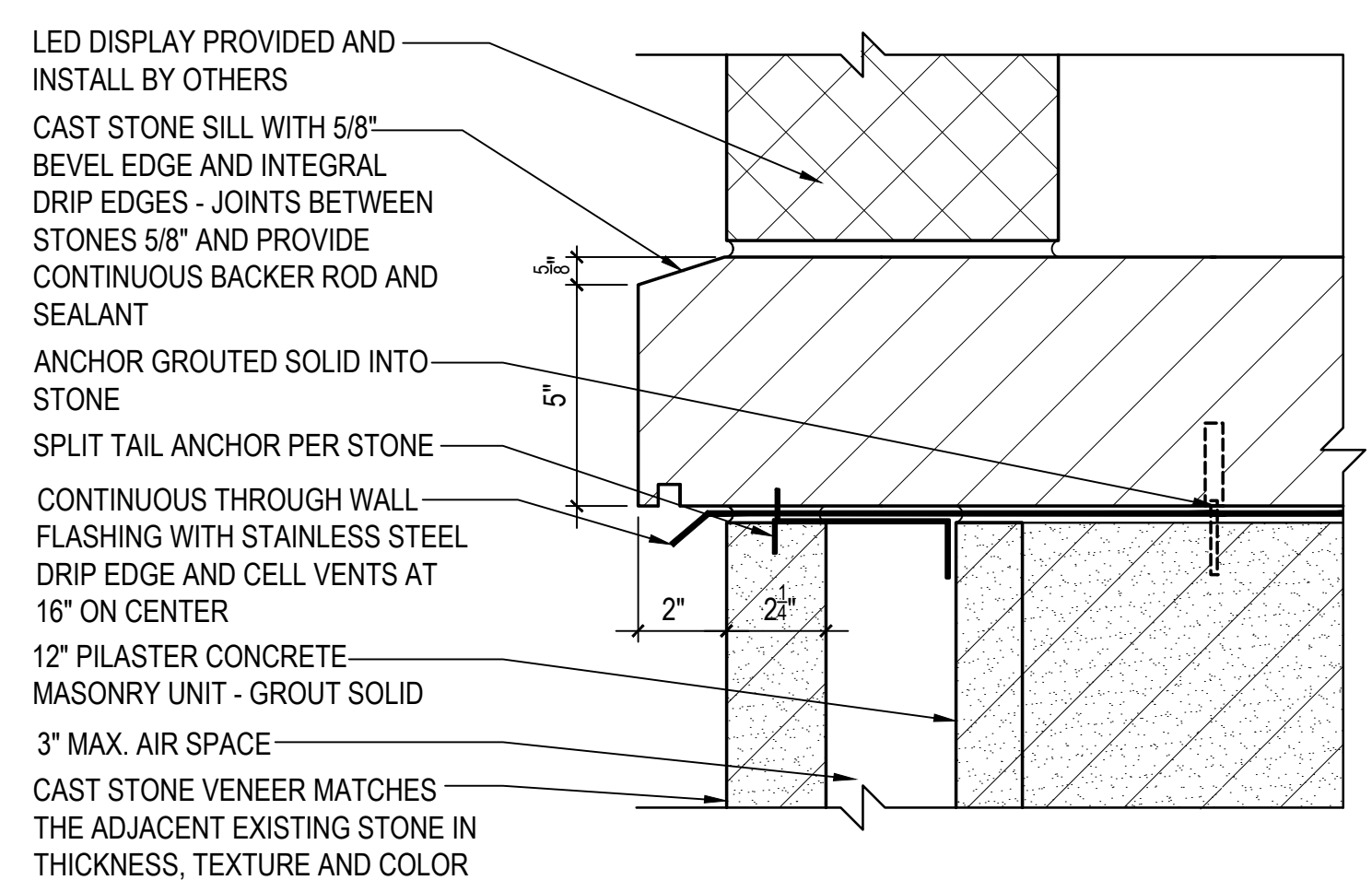

**6 SILL DETAIL**  
1/2" = 1'-0"

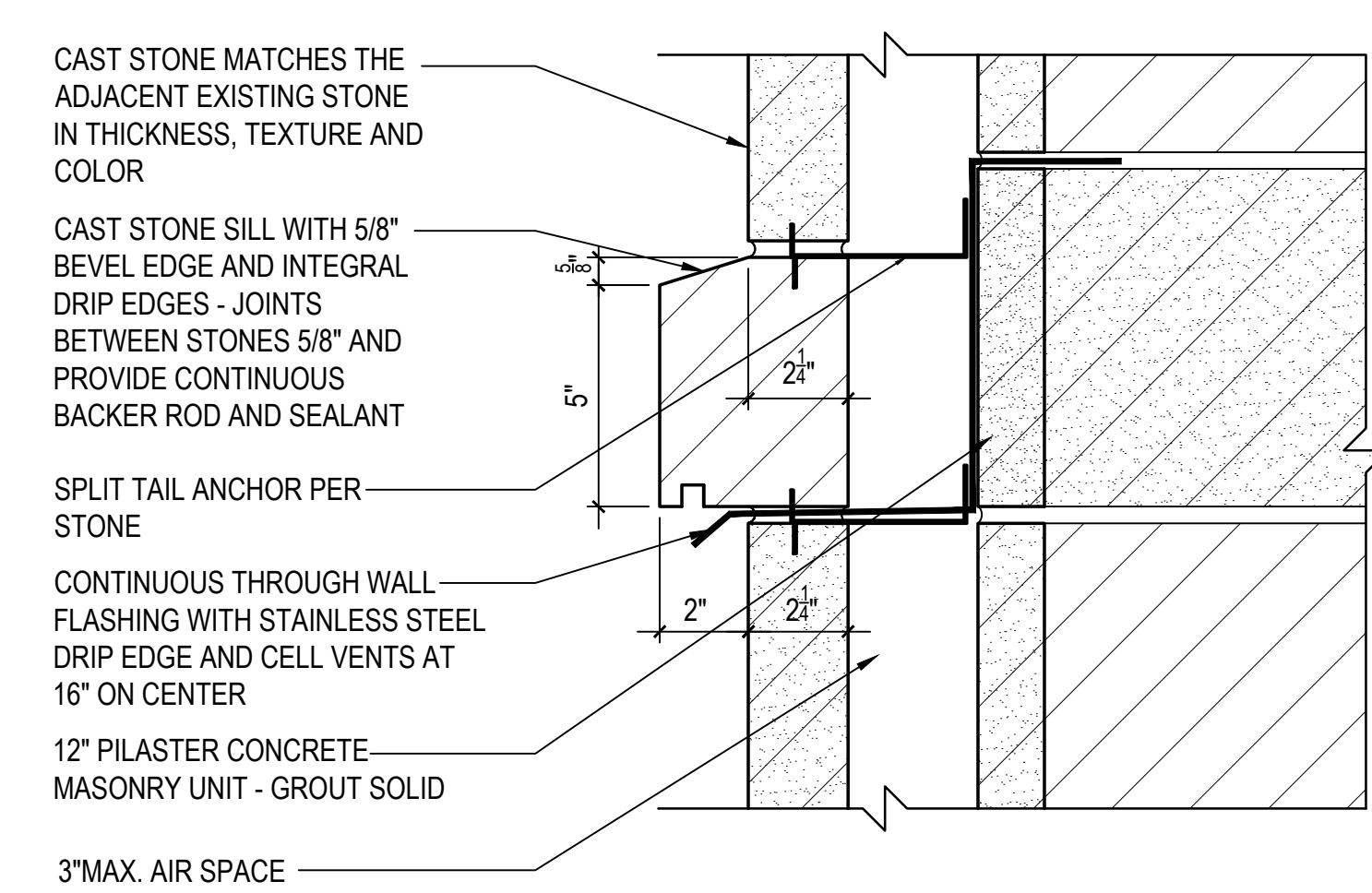

**7 SILL DETAIL**  
1/2" = 1'-0"

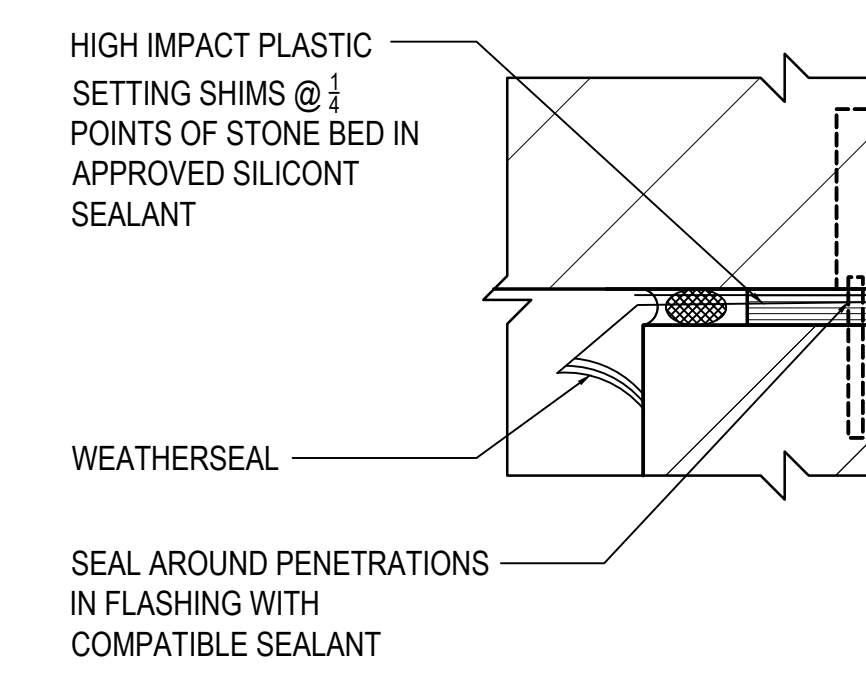

**9 DETAIL**  
6" = 1'-0"



**CASH AND INVESTMENT REPORT FOR FOUNTAINDALE PUBLIC LIBRARY DISTRICT**  
Balance as of 01/31/2025

GL Number	Description	Beginning Balance	Debits	Credits	Ending Balance
<b>CASH</b>					
01-10-1111	Cash Checking/Wintrust Operating	187,791.12	3,959,778.92	3,955,788.35	191,781.69
	Total Operating Fund	187,791.12	3,959,778.92	3,955,788.35	191,781.69
01-10-1130	Cash Checking/Payroll	435,964.21	439,926.26	418,520.91	457,369.56
	Total Payroll Fund	435,964.21	439,926.26	418,520.91	457,369.56
01-10-1150	Petty Cash	2,732.09	0.00	0.00	2,732.09
	Total Petty Cash	2,732.09	0.00	0.00	2,732.09
	<b>Total Cash</b>	<b>626,487.42</b>	<b>4,399,705.18</b>	<b>4,374,309.26</b>	<b>651,883.34</b>
<b>INVESTMENTS</b>					
06-10-1205	Investments - Special Reserve PMA	20,371,438.30	48,331.27	0.00	20,419,769.57
	Total Special Reserve PMA	20,371,438.30	48,331.27	0.00	20,419,769.57
01-10-1210	Illinois Funds - General MM	80,328.94	310.82	0.00	80,639.76
	Total IL Fund - General	80,328.94	310.82	0.00	80,639.76
01-10-1211	Invest/Wintrust MM Account	6,203,134.94	3,193,294.91	3,935,460.51	5,460,969.34
02-10-1211	Invest/Wintrust MM Account	5,760.05	0.00	4,000.00	1,760.05
03-10-1211	Invest/Wintrust MM Account	(5,608.32)	0.00	108,395.96	(114,004.28)
05-10-1211	Invest/Wintrust MM Account	0.18	0.00	0.00	0.18
08-10-1211	Invest/Wintrust MM Account	68,694.12	0.00	23,746.68	44,947.44
10-10-1211	Invest/Money Market Account	123,809.12	0.00	30,590.94	93,218.18
11-10-1211	Invest/Money Market Account	285,174.23	0.00	22,209.08	262,965.15
	Total General Fund	6,680,964.32	3,193,294.91	4,124,403.17	5,749,856.06
01-10-1212	Invest/MM/IL Fund - E-Pay	86,450.57	577.60	10.75	87,017.42
	Total IL Fund - ePay	86,450.57	577.60	10.75	87,017.42
06-10-1211	Invest/Wintrust MM Account	2,875,731.12	11,251.52	0.00	2,886,982.64
	Total Special Reserve Fund	2,875,731.12	11,251.52	0.00	2,886,982.64
07-10-1211	Invest/Wintrust MM Account	1,209,370.03	4,680.39	0.00	1,214,050.42
	Total Working Cash Fund	1,209,370.03	4,680.39	0.00	1,214,050.42
	<b>Total Investments</b>	<b>31,304,283.28</b>	<b>3,258,446.51</b>	<b>4,124,413.92</b>	<b>30,438,315.87</b>
<b>BOND FUND</b>					
04-40-1211	Invest/Wintrust MM Account	3,328,466.46	7,430.31	2,951,425.00	384,471.77
	Total Bond Fund	3,328,466.46	7,430.31	2,951,425.00	384,471.77
	<b>TOTAL CASH AND INVESTMENTS</b>	<b>35,259,237.16</b>	<b>7,665,582.00</b>	<b>11,450,148.18</b>	<b>31,474,670.98</b>

Special Reserve PMA -3.807%  
IL Fund General - 4.556%  
Money Market - Wintrust - 4.606%

REVENUE REPORT FOR FOUNTAINDALE PUBLIC LIBRARY DISTRICT  
Balance As Of 01/31/2025

GL Number	Description	Activity For 01/31/2025 Increase (Decrease)	YTD Balance 01/31/2025 Normal (Abnormal)	% Bdgt Used	24-25 Amended Budget	Available Balance 01/31/2025 Normal (Abnormal)
Revenues						
01 - General Fund						
01-10-3140	Property Tax - Will Back Taxes		7,694.71	153.89	5,000.00	(2,694.71)
01-10-3141	Property Tax - Dupage Back Taxes		433.85	108.46	400.00	(33.85)
01-10-3150	PROPERTY TAX - WILL 2024			0.00	5,089,197.00	5,089,197.00
01-10-3151	PROPERTY TAX - DUPAGE 2024			0.00	103,861.00	103,861.00
01-10-3162	Property Tax - Will 2023		4,413,555.59	86.54	5,099,841.00	686,285.41
01-10-3163	Property Tax - DuPage 2023		84,922.97	81.60	104,078.00	19,155.03
01-10-3190	Replacement Tax	28,844.99	128,494.01	58.41	220,000.00	91,505.99
01-10-3211	Interest - Invest. MM Accounts	24,724.26	202,250.85	86.06	235,000.00	32,749.15
01-10-3212	Interest - Money Market			0.00	10.00	10.00
01-10-3215	Interest on Collected Taxes		328.84	328.84	100.00	(228.84)
01-10-3310	Revenue - Circulation Fees - Epay	1,288.11	8,740.27	97.11	9,000.00	259.73
01-10-3311	Revenue - Circulation Fees	217.38	1,164.55	77.64	1,500.00	335.45
01-10-3410	Revenue - Copy Machines	368.55	2,729.87	91.00	3,000.00	270.13
01-10-3430	Revenue - Printing	1,174.64	8,324.27	83.24	10,000.00	1,675.73
01-10-3440	Revenue - Fax Machine	323.79	2,232.06	111.60	2,000.00	(232.06)
01-10-3511	Miscellaneous Income	58.25	1,071.65	71.44	1,500.00	428.35
01-10-3512	Auto License Plate Sticker Income	98.25	6,849.50	136.99	5,000.00	(1,849.50)
01-10-3515	Donations Received		7,749.99	56.57	13,700.00	5,950.01
01-10-3613	Miscellaneous Reimbursements		10,017.32	500.87	2,000.00	(8,017.32)
01-10-3614	Staff Purchases & Reimbursements	58.07	2,569.39	321.17	800.00	(1,769.39)
01-10-3616	Board Reimbursements	29.80	89.40	44.70	200.00	110.60
01-10-3830	Funds Transfer In		500.00	100.00	0.00	(500.00)
01-10-3910	State Grant		99,567.77	100.00	99,568.00	0.23
01-10-3930	Other Grant Income			0.00	250,000.00	250,000.00
<b>Total 01 - General Fund:</b>		<b>57,186.09</b>	<b>4,989,286.86</b>	<b>44.33</b>	<b>11,255,755.00</b>	<b>6,266,468.14</b>
02 - Audit Fund						
02-10-3162	Property Tax - Will 2023		3,847.35	100.00	0.00	(3,847.35)
02-10-3163	Property Tax - DuPage 2023		74.37	100.00	0.00	(74.37)
<b>Total 02 - Audit Fund:</b>		<b>0.00</b>	<b>3,921.72</b>	<b>100.00</b>	<b>0.00</b>	<b>(3,921.72)</b>

03 - Liability Fund							
03-10-3162	Property Tax - Will 2023		26,290.25	100.00	0.00	(26,290.25)	
03-10-3163	Property Tax - DuPage 2023		508.22	100.00	0.00	(508.22)	
Total 03 - Liability Fund:		0.00	26,798.47	100.00	0.00	(26,798.47)	
04 - Bond Fund							
04-40-3150	PROPERTY TAX - WILL 2024			0.00	1,526,613.00	1,526,613.00	
04-40-3151	PROPERTY TAX - DUPAGE 2024			0.00	31,155.00	31,155.00	
04-40-3162	Property Tax - Will 2023		1,444,039.98	102.32	1,411,294.00	(32,745.98)	
04-40-3163	Property Tax - DuPage 2023		28,063.88	97.44	28,802.00	738.12	
04-40-3211	Interest - Invest. MM Accounts	7,430.31	73,831.61	123.05	60,000.00	(13,831.61)	
Total 04 - Bond Fund:		7,430.31	1,545,935.47	50.56	3,057,864.00	1,511,928.53	
06 - Special Reserve Fund							
06-10-3211	Interest - Invest. MM Accounts	11,251.52	99,690.47	99.69	100,000.00	309.53	
06-10-3222	Change In Market Value	48,331.27	547,874.42	109.57	500,000.00	(47,874.42)	
Total 06 - Special Reserve Fund:		59,582.79	647,564.89	107.93	600,000.00	(47,564.89)	
07 - Working Cash Fund							
07-10-3211	Interest - Invest. MM Accounts	4,680.39	35,486.93	118.29	30,000.00	(5,486.93)	
Total 07 - Working Cash Fund:		4,680.39	35,486.93	118.29	30,000.00	(5,486.93)	
08 - Maintenance Fund							
08-10-3162	Property Tax - Will 2023		192,367.66	100.00	0.00	(192,367.66)	
08-10-3163	Property Tax - DuPage 2023		3,706.31	100.00	0.00	(3,706.31)	
Total 08 - Maintenance Fund:		0.00	196,073.97	100.00	0.00	(196,073.97)	
10 - Social Security Fund							
10-10-3162	Property Tax - Will 2023		216,093.01	100.00	0.00	(216,093.01)	
10-10-3163	Property Tax - DuPage 2023		4,164.95	100.00	0.00	(4,164.95)	
Total 10 - Social Security Fund:		0.00	220,257.96	100.00	0.00	(220,257.96)	
11 - IMRF Fund							
11-10-3162	Property Tax - Will 2023		108,367.12	100.00	0.00	(108,367.12)	
11-10-3163	Property Tax - DuPage 2023		2,082.49	100.00	0.00	(2,082.49)	

Total 11 - IMRF Fund:	0.00	110,449.61	100.00	0.00	(110,449.61)
Revenues	<u>128,879.58</u>	<u>7,775,775.88</u>	<u>52.03</u>	<u>14,943,619.00</u>	<u>7,167,843.12</u>
Report Totals:					
<b>TOTAL REVENUES - ALL FUNDS</b>	<b>128,879.58</b>	<b>7,775,775.88</b>		<b>14,943,619.00</b>	<b>7,167,843.12</b>

**EXPENDITURE REPORT FOR FOUNTAINDALE PUBLIC LIBRARY DISTRICT**  
**Balance as of 01/31/2025**

GL Number	Description	Activity For 01/31/2025 Increase (Decrease)	YTD Balance 01/31/2025 Normal (Abnormal)	% Bdgt Used	24-25 Amended Budget	Available Balance 01/31/2025 Normal (Abnormal)
<b>Fund: 01 General Fund</b>						
<b>Account Category: Expenditures</b>						
[None]	FUND TRANSFER		500.00	100.00	0.00	(500.00)
PR EXP	PERSONNEL EXPENSE	464,717.11	3,352,281.40	51.68	6,487,116.00	3,134,834.60
CONTRACT	CONTRACT SERVICES	21,334.66	312,222.39	50.33	620,384.00	308,161.61
SUPPLIES	SUPPLIES & UTILITIES	22,897.07	253,629.57	35.95	705,600.00	451,970.43
LIBRARY	LIBRARY MATERIALS	58,205.78	512,113.36	37.27	1,374,100.00	861,986.64
CAPITAL	CAPITAL EXPENDITURES	4,140.96	45,404.41	17.66	257,040.00	211,635.59
MISC	MISCELLANOUS EXPENDITURES	3,743.03	31,317.61	38.66	81,000.00	49,682.39
GRANTPR	GRANT PROJECT			0.00	349,568.00	349,568.00
	Expenditures	<u>575,038.61</u>	<u>4,506,968.74</u>	<u>45.65</u>	<u>9,874,808.00</u>	<u>5,367,339.26</u>
Fund 01 - General Fund:						
<b>TOTAL EXPENDITURES</b>		<b>575,038.61</b>	<b>4,506,968.74</b>		<b>9,874,808.00</b>	<b>5,367,339.26</b>
<b>Fund: 02 Audit Fund</b>						
<b>Account Category: Expenditures</b>						
CONTRACT	CONTRACT SERVICES		12,055.00	48.22	25,000.00	12,945.00
	Expenditures	<u>0.00</u>	<u>12,055.00</u>	<u>48.22</u>	<u>25,000.00</u>	<u>12,945.00</u>
Fund 02 - Audit Fund:						
<b>TOTAL EXPENDITURES</b>		<b>0.00</b>	<b>12,055.00</b>		<b>25,000.00</b>	<b>12,945.00</b>
<b>Fund: 03 Liability Insurance Fund</b>						
<b>Account Category: Expenditures</b>						
PR EXP	PERSONNEL EXPENSE - UNEMPLOYMENT INS	18,728.00	21,401.88	48.64	44,000.00	22,598.12
INS	LIABILITY INSURANCE	89,667.96	89,667.96	82.64	108,500.00	18,832.04
	Expenditures	<u>108,395.96</u>	<u>111,069.84</u>	<u>72.83</u>	<u>152,500.00</u>	<u>41,430.16</u>
Fund 03 - Liability Insurance Fund:						
<b>TOTAL EXPENDITURES</b>		<b>108,395.96</b>	<b>111,069.84</b>		<b>152,500.00</b>	<b>41,430.16</b>
<b>Fund: 04 Bond Fund</b>						
<b>Account Category: Expenditures</b>						
BONDFUND	BOND FUND	2,951,425.00	3,247,850.00	100.00	3,247,850.00	0.00
	Expenditures	<u>2,951,425.00</u>	<u>3,247,850.00</u>	<u>100.00</u>	<u>3,247,850.00</u>	<u>0.00</u>
Fund 04 - Bond Fund:						
<b>TOTAL EXPENDITURES</b>		<b>2,951,425.00</b>	<b>3,247,850.00</b>		<b>3,247,850.00</b>	<b>0.00</b>

**Fund: 06 Special Reserve Fund**

**Account Category: Expenditures**

CONTRACT	CONTRACT SERVICES			0.00	100.00	100.00
CAPITAL	CAPITAL EXPENDITURES	203,236.16	800,535.48	29.70	2,695,000.00	1,894,464.52
Expenditures		203,236.16	800,535.48	29.70	2,695,100.00	1,894,564.52

Fund 06 - Special Reserve Fund:  
TOTAL EXPENDITURES

203,236.16      800,535.48      2,695,100.00      1,894,564.52

**Fund: 08 Maintenance Fund**

**Account Category: Expenditures**

CONTRACT	CONTRACT SERVICES	21,152.02	137,336.91	30.12	456,000.00	318,663.09
SUPPLIES	SUPPLIES & UTILITIES	2,594.66	18,372.02	40.83	45,000.00	26,627.98
Expenditures		23,746.68	155,708.93	31.08	501,000.00	345,291.07

Fund 08 - Maintenance Fund:  
TOTAL EXPENDITURES

23,746.68      155,708.93      501,000.00      345,291.07

**Fund: 10 Social Security Fund**

**Account Category: Expenditures**

PR EXP	PERSONNEL EXPENSE - FICA	30,590.94	225,927.51	49.05	460,640.00	234,712.49
Expenditures		30,590.94	225,927.51	49.05	460,640.00	234,712.49

Fund 10 - Social Security Fund:  
TOTAL EXPENDITURES

30,590.94      225,927.51      460,640.00      234,712.49

**Fund: 11 IMRF Fund**

**Account Category: Expenditures**

PR EXP	PERSONNEL EXPENSE - IMRF	22,209.08	163,829.90	47.42	345,480.00	181,650.10
Expenditures		22,209.08	163,829.90	47.42	345,480.00	181,650.10

Fund 11 - IMRF Fund:  
TOTAL EXPENDITURES

22,209.08      163,829.90      345,480.00      181,650.10

Report Totals:

**TOTAL EXPENDITURES - ALL FUNDS**

**3,914,642.43      9,223,945.40      17,302,378.00      8,077,932.60**

---

Kathy J. Spindel/Treasurer

BILLS PAID REPORT FOR FOUNTAINDALE PUBLIC LIBRARY DISTRICT  
FEBRUARY 2025

Check Date	Check Number	Payee	Description	GL Number	Amount Paid
02/01/2025	1300E	AFLAC	JAN. 2025 EMPLOYER CONTRIBUTIONS	01-10-4192	\$15.08
02/01/2025	1301E	Illinois Municipal Retirement Fund	JAN. 2025 EMPLOYER CONTRIBUTIONS	11-10-4142	\$23,253.13
02/01/2025	61736	Blue Cross Blue Shield of Illinois	FEB. 2025 EMPLOYER CONTRIBUTIONS	01-10-4192	\$42,654.88
02/01/2025	61737	Dearborn National Life Insurance Co	FEB. 2025 EMPLOYER CONTRIBUTIONS	01-10-4192	\$619.10
02/01/2025	61738	FIDELITY SECURITY LIFE INSURANCE/EYEMED	FEB. 2025 EMPLOYER CONTRIBUTIONS	01-10-4192	\$315.44
02/01/2025	61739	LIMRICC UNEMPLOYMENT COMPENSATION GROUP	UNEMPLOYMENT INSURANCE: 4 QUARTER ENDING 12/31/24	03-10-4143	\$277.89
					\$67,135.52

-- TOTAL BY PAYROLL & FICA --  
 Gross Pay \$409,335.32  
 FICA \$30,590.94  
 Gross Pay & FICA \$439,926.26

  
 \_\_\_\_\_  
 Jennie Nguyen/Finance Manager

**BOARD REPORT FOR FOUNTAINDALE PUBLIC LIBRARY DISTRICT**  
JANUARY 2025

Payee	Description	GL Number	Amount Paid
Celeste M. Bermejo	Reimbursement of additional board box meals - 01/16/2025	01-10-3616	\$29.80
			<u><b>\$29.80</b></u>



FOUNTAINDALE PUBLIC LIBRARY DISTRICT  
 BILLS PAYABLES REPORT  
 FEBRUARY 20, 2025

Invoice Number	Vendor Name	Description	Distributions\Amounts	Invoice Date	Inv Amt
<b>ABCO ELECTRICAL CONSTRUCTION &amp; DESIGN LLC</b> 17141	ABCO ELECTRICAL CONSTRUCTION & DESIGN LLC	3RD FLOOR ELECTRICAL WORK	08-30-4211 3,747.00	01/15/2025	3,747.00
Total ABCO ELECTRICAL CONSTRUCTION & DESIGN LLC:					3,747.00
<b>Al Warren Oil Co., Inc.</b> w1718326	Al Warren Oil Co., Inc.	GENERATOR DIESEL	08-30-4211 798.89	01/23/2025	798.89
Total Al Warren Oil Co., Inc.:					798.89
<b>Allyse Schiller</b> AS012725	Allyse Schiller	FINANCE IRS FORMS REIMBURSEMENT	01-10-4351 14.99	01/27/2025	14.99
Total Allyse Schiller:					14.99
<b>Alonti Catering</b> M4566-FEB25	Alonti Catering	BOARD MEETING DINNERS: 1/16/25	01-16-4355 167.42 01-16-4355 17.00	01/31/2025	184.42
M4566-FEB25	Alonti Catering	PINNACLE STRATEGIC PLANNING MEETING LUNCHES	01-10-4715 308.55 01-10-4715 31.00	01/31/2025	339.55
Total Alonti Catering:					523.97
<b>Amazon</b> 3661	Amazon	CREDITED UNDELIVERED ITEMS	01-27-4353 (42.99)	01/31/2025	(42.99)
3661	Amazon	REORDERED UNDELIVERED ITEMS	01-27-4353 29.99	01/31/2025	29.99
3710	Amazon	VARIOUS SUPPLIES	01-27-4353 8.99 01-27-4371 14.99 01-27-4371 28.42 01-27-4371 19.99 01-27-4371 59.99 01-27-4371 29.02 01-27-4371 7.98 01-27-4568 12.80	01/31/2025	182.18
3713	Amazon	PROGRAM SUPPLIES	01-24-4353 19.98 01-24-4353 8.85 01-24-4353 5.29 01-24-4353 6.99 01-24-4353 35.90 01-24-4353 8.72	01/31/2025	85.73
3714	Amazon	WINTER PROGRAM SUPPLIES	01-20-4353 17.99	01/31/2025	17.99
3724	Amazon	VARIOUS SUPPLIES	01-14-4354 215.60 01-14-4354 41.60 01-14-4354 18.12 01-14-4641 562.16	01/31/2025	837.48
3728	Amazon	CHEWLERY SUPPLIES	01-20-4371 8.99 01-20-4371 9.98 01-20-4371 7.98	01/31/2025	26.95
3732	Amazon	SPRING SUPPLIES	01-27-4371 66.00 01-27-4353 15.95	01/31/2025	81.95
3734	Amazon	NOTARY BAGS	01-10-4351 155.92	01/31/2025	155.92
3746	Amazon	VARIOUS SUPPLIES	01-28-4371 6.43 01-28-4353 9.98 01-28-4371 29.99 01-28-4353 6.89	01/31/2025	53.29
3750	Amazon	GOLDEN GIRLS PROGRAM SUPPLIES	01-24-4353 15.99 01-24-4353 5.57	01/31/2025	21.56
3752	Amazon	PATRON GUEST PASS PRINTER	01-14-4641 164.20	01/31/2025	164.20

FOUNTAINDALE PUBLIC LIBRARY DISTRICT  
 BILLS PAYABLES REPORT  
 FEBRUARY 20, 2025

Invoice Number	Vendor Name	Description	Distributions\Amounts	Invoice Date	Inv Amt
<b>Amazon</b>					
3757	Amazon	PROGRAM SUPPLIES	01-20-4353 62.97 01-20-4353 49.45	01/31/2025	112.42
3760	Amazon	OUTREACH - WATER SUPPLIES	01-10-4351 58.60	01/31/2025	58.60
3761	Amazon	MAKER SUPPLIES	01-27-4371 24.99 01-27-4371 15.98 01-27-4371 20.99 01-27-4371 15.98 01-27-4371 14.98 01-27-4371 22.98 01-27-4371 15.83 01-27-4353 25.70	01/31/2025	157.43
3762	Amazon	MAKER GEAR	01-27-4568 14.44 01-27-4568 1,179.99 01-27-4353 32.99 01-27-4353 14.89	01/31/2025	1,242.31
3765	Amazon	PROGRAM SUPPLIES	01-24-4353 37.62 01-24-4353 29.98 01-24-4353 37.98	01/31/2025	105.58
3774	Amazon	MAKER & PROGRAM SUPPLIES	01-27-4568 31.00 01-27-4568 129.99 01-27-4568 36.99 01-27-4568 19.99 01-27-4371 39.90 01-27-4353 27.98 01-27-4353 9.98 01-27-4371 51.96	01/31/2025	347.79
3778	Amazon	DOGMAN PROGRAM SUPPLIES	01-20-4353 16.65 01-20-4353 21.60 01-20-4353 18.78 01-20-4353 19.99 01-20-4353 11.94	01/31/2025	88.96
3782	Amazon	VARIOUS EQUIPMENT	01-27-4568 25.78 01-27-4371 11.96 01-27-4568 17.88 01-27-4568 29.69	01/31/2025	85.31
3791	Amazon	VARIOUS SUPPLIES & EQUIPMENT	01-14-4641 449.97 01-14-4354 203.94 01-14-4354 113.04 01-14-4354 23.98 01-14-4354 21.99	01/31/2025	812.92
3794	Amazon	DUMPSTER GATE HASP	01-30-4392 37.10	01/31/2025	37.10
3797	Amazon	SUMMER PROGRAM SUPPLIES	01-27-4353 14.22 01-27-4353 46.94 01-27-4353 8.46	01/31/2025	69.62

FOUNTAINDALE PUBLIC LIBRARY DISTRICT  
 BILLS PAYABLES REPORT  
 FEBRUARY 20, 2025

Invoice Number	Vendor Name	Description	Distributions\Amounts	Invoice Date	Inv Amt
<b>Amazon</b> 3800	Amazon	TEEN PROGRAM & VORTEX SUPPLIES	01-24-4353 9.99 01-24-4353 13.99 01-24-4353 11.68 01-24-4353 11.98 01-24-4353 12.99 01-24-4353 16.99 01-24-4353 19.96 01-24-4353 29.79 01-24-4353 9.99 01-24-4353 52.98 01-24-4353 59.96 01-24-4353 19.98 01-24-4353 16.96 01-24-4353 37.96 01-24-4353 98.99	01/31/2025	424.19
3801	Amazon	TEEN & SPRING PROGRAM SUPPLIES	01-24-4353 8.99 01-24-4353 9.94 01-24-4353 30.78 01-24-4353 20.97 01-24-4353 5.99 01-24-4353 4.49 01-24-4353 9.79 01-24-4353 8.99 01-24-4353 8.99 01-24-4353 9.99 01-24-4353 68.99	01/31/2025	187.91
3804	Amazon	PROGRAM WATER DISPENSER	01-24-4353 39.99	01/31/2025	39.99
3805	Amazon	FINANCE SUPPLIES	01-10-4351 9.95 01-10-4351 15.87 01-10-4351 9.89 01-10-4351 11.69 01-10-4351 17.99 01-10-4351 24.99	01/31/2025	90.38
3811	Amazon	PHONE & RADIO HOLSTERS	08-30-4357 23.98 08-30-4357 51.64	01/31/2025	75.62
3827	Amazon	PROGRAM SUPPLIES	01-24-4353 14.96 01-24-4353 15.50 01-24-4353 17.95 01-24-4353 4.99	01/31/2025	53.40
3832	Amazon	STORAGE & PROGRAM SUPPLIES	01-28-4371 34.99 01-28-4371 86.99	01/31/2025	121.98
Total Amazon:					5,725.76
<b>AMAZON CAPITAL SERVICES COLLECTIONS</b>					
1D47-Q3PX- QJWW	Amazon Capital Services	ADULT NONFICTION BOOKS	01-26-4541 115.99 01-26-4518 4.99	12/18/2024	120.98
1CNG-4QNF- 1GK7	Amazon Capital Services	JUVENILE DVD	01-26-4558 38.20	12/19/2024	38.20
1CWQ-KVKD- 631R	Amazon Capital Services	ADULT NONFICTION BOOKS	01-26-4541 16.99	12/19/2024	16.99
1QJY-K69L- JNML	Amazon Capital Services	ADULT VIDEO GAMES	01-26-4565 29.99	12/20/2024	29.99
174X-DKMH- P9JL	Amazon Capital Services	ADULT WORLD LANGUAGES	01-26-4525 84.46	12/21/2024	84.46
11RP-7GCR- NXPC	Amazon Capital Services	YOUNG ADULT FICTION BOOKS	01-26-4548 24.00	12/21/2024	24.00

FOUNTAINDALE PUBLIC LIBRARY DISTRICT  
 BILLS PAYABLES REPORT  
 FEBRUARY 20, 2025

Invoice Number	Vendor Name	Description	Distributions\Amounts	Invoice Date	Inv Amt
<b>AMAZON CAPITAL SERVICES COLLECTIONS</b>					
11RP-7GCR-RVDW	Amazon Capital Services	JUVENILE VIDEO GAMES	01-26-4564 24.99	12/21/2024	24.99
13WT-J1TG-VLYC	Amazon Capital Services	YOUNG ADULT VIDEO GAMES	01-26-4563 39.99	12/21/2024	39.99
1F93-LLMG-PPYY	Amazon Capital Services	ADULT FICTION BOOKS	01-26-4540 26.96	12/21/2024	26.96
1YP7-LDMT-P9HP	Amazon Capital Services	ADULT NONFICTION BOOKS	01-26-4541 28.31	12/21/2024	28.31
1VP7-1PH9-YG1M	Amazon Capital Services	JUVENILE DVD	01-26-4558 70.33	12/22/2024	70.33
14JV-6WL3-99K9	Amazon Capital Services	ADULT NONFICTION BOOKS	01-26-4541 22.17	12/23/2024	22.17
14V1-HYKN-4PG7	Amazon Capital Services	ADULT FICTION BOOKS	01-26-4540 316.72	12/23/2024	316.72
1FXY-6WCN-4YTV	Amazon Capital Services	ADULT FICTION BOOKS	01-26-4540 47.98	12/23/2024	47.98
1W9V-K116-4NG7	Amazon Capital Services	JUVENILE DVD	01-26-4558 29.46	12/23/2024	29.46
14V1-HYKN0D1NW	Amazon Capital Services	YOUNG ADULT VIDEO GAMES	01-26-4563 61.90	12/24/2024	61.90
1FQG-MFL9-CYWQ	Amazon Capital Services	JUVENILE DVD	01-26-4558 9.99	12/24/2024	9.99
1473-6PCK-G46L	Amazon Capital Services	ADULT VIDEO GAMES	01-26-4565 39.99	12/26/2024	39.99
17X7-RF7W-VNJJ	Amazon Capital Services	JUVENILE DVD	01-26-4558 29.89	12/27/2024	29.89
1GNP-9GDM-XTQM	Amazon Capital Services	ADULT DVD	01-26-4557 27.03	12/27/2024	27.03
1D6J-H1RJ-6VTJ	Amazon Capital Services	ADULT NONFICTION BOOKS	01-26-4541 461.23	12/28/2024	461.23
1YMM-PY4H-71LW	Amazon Capital Services	CREDITED LOST ITEMS	01-26-4541 (304.81)	12/28/2024	(304.81)
1QK4-JLYP-4QHG	Amazon Capital Services	ADULT WORLD LANGUAGES	01-26-4525 18.95	12/28/2024	18.95
11VH-WR6T-GFTM	Amazon Capital Services	ADULT NONFICTION BOOKS	01-26-4541 344.51	12/29/2024	344.51
1GNX-4HGC-3WNM	Amazon Capital Services	ADULT FICTION BOOKS	01-26-4540 34.56	12/30/2024	34.56
1KNR-NVRJ-MXWH	Amazon Capital Services	ADULT NONFICTION BOOKS	01-26-4541 17.06	01/02/2025	17.06
1XFC-9HR4-NPF4	Amazon Capital Services	ADULT NONFICTION BOOKS	01-26-4541 15.55	01/02/2025	15.55
1KHN-PW7N-RW4C	Amazon Capital Services	ADULT NONFICTION BOOKS	01-26-4541 29.95	01/06/2025	29.95
167X-GHJ6-XW3M	Amazon Capital Services	ADULT VIDEO GAMES	01-26-4565 68.98	01/07/2025	68.98
1XDG-GFJV-HXJN	Amazon Capital Services	ADULT FICTION BOOKS	01-26-4540 52.82	01/09/2025	52.82
143Q-Q3V1-3JXX	Amazon Capital Services	ADULT MUSIC	01-26-4550 31.96	01/11/2025	31.96
149V-NJFY-WFL3	Amazon Capital Services	JUVENILE VIDEO GAMES	01-26-4564 24.99	01/11/2025	24.99
149V-NJFY-XLX1	Amazon Capital Services	ADULT FICTION BOOKS	01-26-4540 28.78	01/11/2025	28.78

FOUNTAINDALE PUBLIC LIBRARY DISTRICT  
 BILLS PAYABLES REPORT  
 FEBRUARY 20, 2025

Invoice Number	Vendor Name	Description	Distributions\Amounts	Invoice Date	Inv Amt
<b>AMAZON CAPITAL SERVICES COLLECTIONS</b>					
11NY-JLPM-7NYH	Amazon Capital Services	ADULT NONFICTION BOOKS	01-26-4541 31.70	01/12/2025	31.70
1LV6-P4F4-996L	Amazon Capital Services	JUVENILE VIDEO GAMES	01-26-4564 24.99	01/12/2025	24.99
1LV6-P4F4-9FD4	Amazon Capital Services	ADULT DVD	01-26-4557 37.22	01/12/2025	37.22
177R-N6J7-4YPR	Amazon Capital Services	CREDITED ADULT DVD	01-26-4557 (4.68)	01/12/2025	(4.68)
1P11-NDW6-113R	Amazon Capital Services	JUVENILE VIDEO GAMES	01-26-4564 34.99	01/12/2025	34.99
1WGP-3F3F-9P7J	Amazon Capital Services	ADULT DVD	01-26-4557 35.92	01/12/2025	35.92
11NY-JLPM-GTW1	Amazon Capital Services	CIRCULATING DEVICES & EQUIPMENT	01-26-4527 239.99	01/13/2025	239.99
14QH-XJJ7-LMX3	Amazon Capital Services	ADULT FICTION BOOKS	01-26-4540 39.96	01/13/2025	39.96
1DJ1-JQT9-DKYD	Amazon Capital Services	ADULT NONFICTION BOOKS	01-26-4541 61.95 01-26-4518 3.99	01/13/2025	65.94
1VL4-43C1-HY1J	Amazon Capital Services	ADULT FICTION BOOKS	01-26-4540 175.34	01/13/2025	175.34
13DF-6CQY-13LY	Amazon Capital Services	ADULT VIDEO GAMES	01-26-4565 89.49	01/14/2025	89.49
16LK-TQMD-TQX9	Amazon Capital Services	ADULT DVD	01-26-4557 12.99	01/14/2025	12.99
1RRP-6414-114J	Amazon Capital Services	ADULT FICTION BOOKS	01-26-4540 107.76	01/15/2025	107.76
1VWD-1FFM-3VTY	Amazon Capital Services	ADULT FICTION BOOKS	01-26-4540 131.04	01/15/2025	131.04
164P-KH6P-DWCQ	Amazon Capital Services	ADULT NONFICTION BOOKS	01-26-4541 35.33	01/16/2025	35.33
17QY-P3PC-F6XQ	Amazon Capital Services	ADULT NONFICTION BOOKS	01-26-4541 205.73	01/16/2025	205.73
1GYT-P3FN-CGXH	Amazon Capital Services	YOUNG ADULT VIDEO GAMES	01-26-4563 49.99	01/16/2025	49.99
1J1W-JRWT-FCJM	Amazon Capital Services	ADULT NONFICTION BOOKS	01-26-4541 17.99	01/16/2025	17.99
1XGD-361P-C36G	Amazon Capital Services	PROCESSING & MENDING SUPPLIES	01-12-4371 11.98 01-12-4371 7.99 01-12-4371 33.49 01-12-4371 35.49 01-12-4371 23.96	01/16/2025	112.91
16PC-WHKP-WHXC	Amazon Capital Services	YOUNG ADULT VIDEO GAMES	01-26-4563 69.99	01/18/2025	69.99
1F9G-TXFD-49NQ	Amazon Capital Services	ADULT DVD	01-26-4557 49.96	01/19/2025	49.96
196R-MC6F-DM6F	Amazon Capital Services	ADULT NONFICTION BOOKS	01-26-4541 149.97	01/20/2025	149.97
19J9-TFCR-FQ9P	Amazon Capital Services	ADULT MUSIC	01-26-4550 13.89	01/20/2025	13.89
174K-R9NQ-QDLL	Amazon Capital Services	CIRCULATING DEVICES & EQUIPMENT	01-26-4527 52.34	01/21/2025	52.34
1DXH-LKFX-NLDT	Amazon Capital Services	YOUNG ADULT VIDEO GAMES	01-26-4563 39.99	01/21/2025	39.99

FOUNTAINDALE PUBLIC LIBRARY DISTRICT  
 BILLS PAYABLES REPORT  
 FEBRUARY 20, 2025

Invoice Number	Vendor Name	Description	Distributions\Amounts		Invoice Date	Inv Amt
<b>AMAZON CAPITAL SERVICES COLLECTIONS</b>						
1M6N-FVHJ-VY31	Amazon Capital Services	YOUNG ADULT VIDEO GAMES	01-26-4563	109.98	01/21/2025	109.98
1N6X-VXR6-K6HX	Amazon Capital Services	ADULT NONFICTION BOOKS	01-26-4541	26.19	01/21/2025	26.19
1PPV-PVF4-RXNH	Amazon Capital Services	ADULT FICTION BOOKS	01-26-4540	67.98	01/21/2025	67.98
139F-6YPW-TCX1	Amazon Capital Services	ADULT FICTION BOOKS	01-26-4540	110.84	01/22/2025	110.84
1D19-4FQ9-W93C	Amazon Capital Services	ADULT DVD	01-26-4557	11.88	01/22/2025	11.88
1MXY-K4T3-XLTR	Amazon Capital Services	ADULT NONFICTION BOOKS	01-26-4541	18.99	01/22/2025	18.99
1WDG-PLR9-VX6N	Amazon Capital Services	JUVENILE VIDEO GAMES	01-26-4564	39.97	01/22/2025	39.97
19T6-WHTT-D36L	Amazon Capital Services	JUVENILE VIDEO GAMES	01-29-4564	130.67	01/23/2025	130.67
19T6-WHTT-DJFQ	Amazon Capital Services	ADULT FICTION BOOKS	01-26-4540	97.40	01/23/2025	97.40
19X9-3J36-FDX6	Amazon Capital Services	ADULT MUSIC	01-26-4550	13.89	01/24/2025	13.89
1T1G-RL11-N79W	Amazon Capital Services	ADULT FICTION BOOKS	01-26-4540	42.91	01/24/2025	42.91
17PC-FNGT-PYX7	Amazon Capital Services	JUVENILE VIDEO GAMES	01-26-4564	29.99	01/25/2025	29.99
1JYX-YH6N-VJ44	Amazon Capital Services	ADULT VIDEO GAMES	01-26-4565	49.99	01/26/2025	49.99
1W6J-7KYY-V46N	Amazon Capital Services	ADULT FICTION BOOKS	01-26-4540	99.92	01/26/2025	99.92
1TC9-LYPJ-PL7F	Amazon Capital Services	ADULT VIDEO GAMES	01-26-4565	769.40	01/26/2025	769.40
1LCX-WJDL-3TF6	Amazon Capital Services	ADULT FICTION BOOKS	01-26-4540	37.98	01/26/2025	37.98
1G7G-JQGN-3J1G	Amazon Capital Services	ADULT DVD	01-26-4557	63.88	01/26/2025	63.88
1TXR-16YD-31CN	Amazon Capital Services	ADULT DVD	01-26-4557	63.88	01/26/2025	63.88
116M-FC9R-3PDR	Amazon Capital Services	JUVENILE VIDEO GAMES	01-26-4564	49.99	01/27/2025	49.99
1W17-XD1R-7GRT	Amazon Capital Services	ADULT FICTION BOOKS	01-26-4540	36.66	01/27/2025	36.66
1C9L-34RT-34HD	Amazon Capital Services	YOUNG ADULT VIDEO GAMES	01-26-4563	79.99	01/27/2025	79.99
1Q3M-WXGV-FJDN	Amazon Capital Services	CREDITED LOST ITEM	01-26-4527	(56.04)	01/28/2025	(56.04)
1R44-X1TL-H611	Amazon Capital Services	ADULT DVD	01-26-4557	53.56	01/28/2025	53.56
19PJ-GPKQ-GRVM	Amazon Capital Services	ADULT DVD	01-26-4557	36.98	01/28/2025	36.98
1HC4-3MGF-JMF4	Amazon Capital Services	CIRCULATING DEVICES & EQUIPMENT	01-26-4527	111.53	01/28/2025	111.53
1CH1-RJRH-6JVL	Amazon Capital Services	JUVENILE VIDEO GAMES	01-26-4564	49.99	01/29/2025	49.99
1J73-GY1F-67F3	Amazon Capital Services	CREDITED LOST ITEM	01-26-4540	(7.99)	01/29/2025	(7.99)

FOUNTAINDALE PUBLIC LIBRARY DISTRICT  
 BILLS PAYABLES REPORT  
 FEBRUARY 20, 2025

Invoice Number	Vendor Name	Description	Distributions\Amounts	Invoice Date	Inv Amt
<b>AMAZON CAPITAL SERVICES COLLECTIONS</b>					
1VK9-H7YT-1Y43	Amazon Capital Services	ADULT VIDEO GAMES	01-26-4565 89.87	01/30/2025	89.87
13VK-4TXT-CXKP	Amazon Capital Services	YOUNG ADULT VIDEO GAMES	01-26-4563 99.98	01/30/2025	99.98
1PPR-TVYH-LTTV	Amazon Capital Services	YOUNG ADULT VIDEO GAMES	01-26-4563 159.97	01/31/2025	159.97
1XR4-CQVW-QG6M	Amazon Capital Services	ADULT FICTION BOOKS	01-26-4540 18.99	02/01/2025	18.99
1JP9-J17P-VRYN	Amazon Capital Services	JUVENILE VIDEO GAMES	01-26-4564 49.99	02/01/2025	49.99
11WR-G1M6-RLTP	Amazon Capital Services	ADULT FICTION BOOKS	01-26-4540 22.64	02/01/2025	22.64
11L3-DKTQ-VLPT	Amazon Capital Services	JUVENILE VIDEO GAMES	01-26-4564 24.99	02/02/2025	24.99
13GF-DXFG-6P4C	Amazon Capital Services	ADULT VIDEO GAMES	01-26-4565 59.99	02/03/2025	59.99
1QRH-FJCR-HD1V	Amazon Capital Services	JUVENILE VIDEO GAMES	01-26-4564 49.99	02/04/2025	49.99
1L4J-LKWQ-HRXC	Amazon Capital Services	JUVENILE VIDEO GAMES	01-26-4564 49.99	02/04/2025	49.99
11LK-7LD3-JFIN	Amazon Capital Services	ADULT VIDEO GAMES	01-26-4565 34.99	02/04/2025	34.99
1Y4W-PQRX-19K9	Amazon Capital Services	ADULT NONFICTION BOOKS	01-26-4541 26.13	02/05/2025	26.13
1K96-16H4-IDKM	Amazon Capital Services	ADULT NONFICTION BOOKS	01-29-4541 42.70	02/05/2025	42.70
1QVY-3FMQ-MQLC	Amazon Capital Services	ADULT FICTION BOOKS	01-26-4540 47.97	02/05/2025	47.97
1F7C-YVFH-J9TJ	Amazon Capital Services	ADULT VIDEO GAMES	01-26-4565 119.86	02/05/2025	119.86
Total AMAZON CAPITAL SERVICES COLLECTIONS:					6,774.06
<b>American Floor Mats</b>					
1872384	American Floor Mats	WORKROOM & DESK FLOOR MATS	08-30-4211 485.51 08-30-4211 485.51 08-30-4211 498.33 08-30-4211 287.97 08-30-4211 (175.73)	01/07/2025	1,581.59
1885332	American Floor Mats	CIRC WORKROOM FLOOR MATS	08-30-4211 485.51 08-30-4211 272.00 08-30-4211 97.99 08-30-4357 (85.55)	02/06/2025	769.95
Total American Floor Mats:					2,351.54
<b>AMERICAN LIBRARY ASSOCIATION</b>					
2240060	American Library Association	BOYER MEMBERSHIP: 12/1/24-11/30/25	01-10-4161 125.00	01/31/2025	125.00
2362786	American Library Association	DAUNIS, JR. MEMBERSHIP: 11/1/24-10/31/25	01-16-4161 70.00	02/06/2025	70.00
N8770-FEB25	American Library Association	MCCORMACK WEBINAR: 4/1/25	01-10-4151 39.50	01/31/2025	39.50
Total AMERICAN LIBRARY ASSOCIATION:					234.50
<b>Animal Quest Entertainment Inc.</b>					

FOUNTAINDALE PUBLIC LIBRARY DISTRICT  
 BILLS PAYABLES REPORT  
 FEBRUARY 20, 2025

Invoice Number	Vendor Name	Description	Distributions\Amounts	Invoice Date	Inv Amt
<b>Animal Quest Entertainment Inc.</b>					
AQE061225DE POSIT	Animal Quest Entertainment Inc.	PROGRAM DEPOSIT - ANIMAL QUEST SHOW - 6/12/25	01-20-4572 100.00 01-24-4573 100.00	02/06/2025	200.00
AQE063025DE POSIT	Animal Quest Entertainment Inc.	PROGRAM DEPOSIT - MIDSUMMER/ZOO-MING THROUGH SUMMER - 6/30/25	01-20-4572 200.00	02/05/2025	200.00
Total Animal Quest Entertainment Inc.:					400.00
<b>Arthur J. Gallagher Risk Management</b>					
5265080	Arthur J. Gallagher Risk Management	TREASURER'S BOND RENEWAL: 8/9/24-8/8/25	03-10-4422 1,537.00	08/27/2024	1,537.00
Total Arthur J. Gallagher Risk Management:					1,537.00
<b>ASI SIGNAGE</b>					
STLO 31901	ASI SIGNAGE	QUIET READING ROOM LETTERING	01-30-4391 915.00 01-30-4391 1,700.00 01-30-4391 125.00	01/06/2025	2,740.00
Total ASI SIGNAGE:					2,740.00
<b>AT &amp; T</b>					
3107278900	AT & T	VOIP: 1/7/25-2/6/25	01-14-4314 1,212.23	01/07/2025	1,212.23
3117278908	AT & T	INTERNET: 1/7/25-2/6/25	01-14-4314 1,212.23	01/07/2025	1,212.23
5665227908	AT & T	TELEPHONE: 1/7/25-2/6/25	01-14-4312 255.62	01/07/2025	255.62
Total AT & T:					2,680.08
<b>AT &amp; T MOBILITY</b>					
24476043	AT & T MOBILITY	WIRELESS TELEPHONE: 12/10/24-1/9/25	01-14-4311 259.30	01/21/2025	259.30
Total AT & T MOBILITY:					259.30
<b>Baker &amp; Taylor</b>					
2038758544	BAKER & TAYLOR - L414059	LIBRARY COLLECTION MATERIALS	01-26-4526 87.92 01-26-4518 1.76	12/19/2024	89.68
2038779370	BAKER & TAYLOR - L414059	LIBRARY COLLECTION MATERIALS	01-26-4546 87.92 01-26-4526 87.92 01-26-4518 3.52	12/27/2024	179.36
2038754086	BAKER & TAYLOR - L442313	LIBRARY COLLECTION MATERIALS	01-29-4551 46.75 01-26-4518 21.70	12/18/2024	68.45
2038811074	BAKER & TAYLOR - L442313	ADULT AUDIOBOOKS	01-29-4551 35.63	01/16/2025	35.63
2038835375	BAKER & TAYLOR - L414059	LIBRARY COLLECTION MATERIALS	01-26-4546 751.20 01-26-4526 386.88 01-26-4518 22.76	01/21/2025	1,160.84
Total Baker & Taylor:					1,533.96
<b>Baker &amp; Taylor - L315193</b>					
2038754044	Baker & Taylor - L315193	LIBRARY COLLECTION MATERIALS	01-26-4551 46.75 01-26-4518 19.70	12/18/2024	66.45
2038811073	Baker & Taylor - L315193	ADULT AUDIOBOOKS	01-26-4551 34.63	01/15/2025	34.63
Total Baker & Taylor - L315193:					101.08
<b>Baker &amp; Taylor - L420685</b>					
2038772730	Baker & Taylor - L420685	LIBRARY COLLECTION MATERIALS	01-29-4540 186.30 01-29-4541 40.48 01-29-4543 116.97 01-26-4518 23.31	12/27/2024	367.06



FOUNTAINDALE PUBLIC LIBRARY DISTRICT  
 BILLS PAYABLES REPORT  
 FEBRUARY 20, 2025

Invoice Number	Vendor Name	Description	Distributions\Amounts	Invoice Date	Inv Amt
<b>Baker &amp; Taylor - L420685</b>					
2038783612	Baker & Taylor - L420685	LIBRARY COLLECTION MATERIALS	01-29-4540 50.06 01-29-4543 71.97 01-26-4518 11.27	12/30/2024	133.30
2038799708	Baker & Taylor - L420685	LIBRARY COLLECTION MATERIALS	01-29-4540 92.91 01-29-4541 11.99 01-29-4543 54.19 01-26-4518 13.43	01/10/2025	172.52
2038812462	Baker & Taylor - L420685	LIBRARY COLLECTION MATERIALS	01-29-4540 17.25 01-29-4541 23.70 01-29-4543 16.79 01-26-4518 4.49	01/22/2025	62.23
2038830727	Baker & Taylor - L420685	LIBRARY COLLECTION MATERIALS	01-29-4540 258.15 01-29-4541 97.72 01-29-4543 13.19 01-26-4518 33.33	01/23/2025	402.39
Total Baker & Taylor - L420685:					1,137.50
<b>Baker &amp; Taylor - L420686</b>					
2038755310	Baker & Taylor - L420686	LIBRARY COLLECTION MATERIALS	01-26-4540 17.98 01-26-4541 107.76 01-26-4543 34.99 01-26-4525 43.71 01-26-4518 25.59	12/17/2025	230.03
2038762468	Baker & Taylor - L420686	LIBRARY COLLECTION MATERIALS	01-26-4540 274.10 01-26-4541 558.61 01-26-4543 96.68 01-26-4518 99.51	12/20/2024	1,028.90
2038764728	Baker & Taylor - L420686	LIBRARY COLLECTION MATERIALS	01-26-4540 370.39 01-26-4541 1,034.18 01-26-4543 56.59 01-26-4525 174.21 01-26-4518 173.26	12/20/2024	1,808.63
2038766612	Baker & Taylor - L420686	LIBRARY COLLECTION MATERIALS	01-26-4540 417.22 01-26-4541 242.78 01-26-4541 289.14 01-26-4518 98.91	12/23/2024	1,048.05
2038768984	Baker & Taylor - L420686	LIBRARY COLLECTION MATERIALS	01-26-4540 387.72 01-26-4541 348.39 01-26-4543 110.97 01-26-4518 69.88	12/26/2024	916.96
2038772441	Baker & Taylor - L420686	LIBRARY COLLECTION MATERIALS	01-26-4540 84.17 01-26-4541 153.05 01-26-4543 237.64 01-26-4525 23.75 01-26-4518 32.39	12/26/2024	531.00
2038776573	Baker & Taylor - L420686	LIBRARY COLLECTION MATERIALS	01-26-4540 183.17 01-26-4541 238.54 01-26-4543 17.99 01-26-4525 10.17 01-26-4518 53.61	12/30/2024	503.48
2038780885	Baker & Taylor - L420686	LIBRARY COLLECTION MATERIALS	01-26-4540 408.43 01-26-4541 72.62 01-26-4543 35.99 01-26-4525 22.75 01-26-4518 56.23	12/30/2024	596.02

FOUNTAINDALE PUBLIC LIBRARY DISTRICT  
 BILLS PAYABLES REPORT  
 FEBRUARY 20, 2025

Invoice Number	Vendor Name	Description	Distributions\Amounts	Invoice Date	Inv Amt
<b>Baker &amp; Taylor - L420686</b>					
2038778125	Baker & Taylor - L420686	LIBRARY COLLECTION MATERIALS	01-26-4540 268.03 01-26-4541 51.79 01-26-4518 43.14	01/02/2025	362.96
2038783086	Baker & Taylor - L420686	LIBRARY COLLECTION MATERIALS	01-26-4540 225.20 01-26-4541 427.14 01-26-4525 48.38 01-26-4518 75.09	01/02/2025	775.81
2038787102	Baker & Taylor - L420686	LIBRARY COLLECTION MATERIALS	01-26-4540 315.64 01-26-4541 259.72 01-26-4543 19.80 01-26-4518 59.81	01/06/2025	654.97
H71380430	Baker & Taylor - L420686	ADULT MUSIC	01-26-4550 19.17	01/08/2025	19.17
2038792744	Baker & Taylor - L420686	LIBRARY COLLECTION MATERIALS	01-26-4540 506.72 01-26-4541 478.29 01-26-4543 78.60 01-26-4518 123.71	01/02/2025	1,187.32
2038795123	Baker & Taylor - L420686	LIBRARY COLLECTION MATERIALS	01-26-4540 436.81 01-26-4541 337.20 01-26-4543 112.04 01-26-4518 83.52	01/09/2025	969.57
2038803113	Baker & Taylor - L420686	LIBRARY COLLECTION MATERIALS	01-26-4540 900.71 01-26-4541 558.84 01-26-4543 236.41 01-26-4525 199.37 01-26-4518 235.97	01/13/2025	2,131.30
2038820099	Baker & Taylor - L420686	LIBRARY COLLECTION MATERIALS	01-26-4540 766.52 01-26-4541 442.60 01-26-4543 20.40 01-26-4525 31.27 01-26-4518 142.57	01/21/2025	1,403.36
2038823575	Baker & Taylor - L420686	LIBRARY COLLECTION MATERIALS	01-26-4540 544.47 01-26-4541 325.21 01-26-4543 53.98 01-26-4525 13.19 01-26-4518 117.02	01/21/2025	1,053.87
2038827472	Baker & Taylor - L420686	LIBRARY COLLECTION MATERIALS	01-26-4540 305.48 01-26-4541 124.47 01-26-4543 18.00 01-26-4525 22.14 01-26-4518 73.63	01/22/2025	543.72
2038830089	Baker & Taylor - L420686	LIBRARY COLLECTION MATERIALS	01-26-4540 567.77 01-26-4541 378.86 01-26-4518 94.21	01/23/2025	1,040.84
2038846431	Baker & Taylor - L420686	LIBRARY COLLECTION MATERIALS	01-26-4540 237.29 01-26-4541 448.80 01-26-4543 19.20 01-26-4525 69.97 01-26-4518 92.00	01/29/2025	867.26
2038850354	Baker & Taylor - L420686	LIBRARY COLLECTION MATERIALS	01-26-4540 556.89 01-26-4541 583.68 01-26-4543 237.19 01-26-4525 107.06 01-26-4518 143.26	01/31/2025	1,628.08

Total Baker & Taylor - L420686:

19,301.30

Belynda Head

FOUNTAINDALE PUBLIC LIBRARY DISTRICT  
 BILLS PAYABLES REPORT  
 FEBRUARY 20, 2025

Invoice Number	Vendor Name	Description	Distributions\Amounts	Invoice Date	Inv Amt
<b>Belynda Head</b>					
BH030225	Belynda Head	PROGRAM - R&B LINE DANCING - 3/2/25	01-24-4571 145.00	12/09/2024	145.00
Total Belynda Head:					145.00
<b>BEN JANSEN</b>					
BJ020325	BEN JANSEN	IT MILEAGE REIMBURSE: 1/21/25 & 1/30/25	01-10-4171 24.64	02/03/2025	24.64
Total BEN JANSEN:					24.64
<b>Best Quality Cleaning, Inc.</b>					
52596	Best Quality Cleaning, Inc.	SPECIAL CLEAN: 1/6/25 CSD FAMILY RESTROOM	08-30-4211 75.00	01/08/2025	75.00
52629	Best Quality Cleaning, Inc.	SPECIAL CLEAN: 1/17/25 3RD FLOOR STAFF RESTROOM	08-30-4211 75.00	01/21/2025	75.00
52835	Best Quality Cleaning, Inc.	FEB. 2025 CLEANING SERVICE	08-30-4215 9,900.45	02/01/2025	9,900.45
52891	Best Quality Cleaning, Inc.	FEB. 2025 SATURDAY PORTER SERVICE	08-30-4215 523.69	02/01/2025	523.69
Total Best Quality Cleaning, Inc.:					10,574.14
<b>Better Containers Mfg. Co., Inc.</b>					
240622	Better Containers Mfg. Co., Inc.	FPLD "I LOVE MY LIBRARY" BAGS	01-10-4371 3,080.00 01-10-4371 113.75	11/07/2024	3,193.75
Total Better Containers Mfg. Co., Inc.:					3,193.75
<b>Black History Month Awareness Club</b>					
3874	Black History Month Awareness Club	2025 BLACK HISTORY MONTH EVENT GOLD SPONSORSHIP	01-10-4731 500.00	02/04/2025	500.00
Total Black History Month Awareness Club:					500.00
<b>Blackstone Publishing</b>					
2183425	Blackstone Publishing	ADULT AUDIOBOOKS	01-26-4551 159.47	01/06/2025	159.47
Total Blackstone Publishing:					159.47
<b>Boilersource</b>					
89077	Boilersource	REPAIR BOILER PARTS	08-30-4211 7,376.22 08-30-4211 245.76 08-30-4211 44.00	01/24/2025	7,665.98
89189	Boilersource	REPAIR BOILER PARTS	08-30-4211 921.60	02/07/2025	921.60
Total Boilersource:					8,587.58
<b>Bolingbrook High School</b>					
3875	BOLINGBROOK HIGH SCHOOL	2025 BOLINGBROOK HIGH SCHOOL THEATRE SPONSORSHIP	01-10-4731 250.00	02/05/2025	250.00
Total Bolingbrook High School:					250.00
<b>Business Office Systems</b>					
70595	Business Office Systems	CIRC DESK SEAT REPLACEMENT	08-30-4211 393.44 08-30-4211 367.50	01/08/2025	760.94
Total Business Office Systems:					760.94
<b>CANVA</b>					
N8770-FEB25	CANVA	2025 WINTER READING STICKERS	01-10-4256 67.50	01/31/2025	67.50
N8770-FEB25	CANVA	LUCKY DAY STICKERS	01-12-4371 352.00	01/31/2025	352.00
Total CANVA:					419.50

FOUNTAINDALE PUBLIC LIBRARY DISTRICT  
 BILLS PAYABLES REPORT  
 FEBRUARY 20, 2025

Invoice Number	Vendor Name	Description	Distributions\Amounts	Invoice Date	Inv Amt
<b>Carl Crooks</b>					
CC030825	Carl Crooks	PROGRAM - SUBURBAN PARANORMAL SHOWCASE - 3/8/25	01-24-4571 100.00	01/23/2025	100.00
Total Carl Crooks:					100.00
<b>Center Point Large Print</b>					
2140344	Center Point Large Print	ADULT LARGE PRINT BOOKS	01-26-4543 151.02	01/01/2025	151.02
2142814	Center Point Large Print	ADULT LARGE PRINT BOOKS	01-29-4543 27.27	01/03/2025	27.27
2142934	Center Point Large Print	ADULT LARGE PRINT BOOKS	01-26-4543 157.12	01/03/2025	157.12
2144908	Center Point Large Print	ADULT LARGE PRINT BOOKS	01-29-4543 81.16	01/07/2025	81.16
Total Center Point Large Print:					416.57
<b>Christina Theobald</b>					
CT010925	Christina Theobald	PER DIEM: 3/13/25-3/15/25 IUG 2025 CONF.	01-10-4173 322.00	01/09/2025	322.00
Total Christina Theobald:					322.00
<b>Cindy Consalvo</b>					
CC010725	Cindy Consalvo	OUTREACH MILEAGE: 9/3/24- 12/19/24	01-10-4171 157.58	01/07/2025	157.58
Total Cindy Consalvo:					157.58
<b>Cintas Corporation</b>					
8407237860	Cintas Corporation	JAN. 2025 FIRST AID RESTOCK	08-30-4215 503.35	01/24/2025	503.35
Total Cintas Corporation:					503.35
<b>Cintas Corporation #344</b>					
4218957442	Cintas Corporation #344	WEEKLY MAT SERVICE: 1/24/25	08-30-4215 26.29	01/24/2025	26.29
4219689010	Cintas Corporation #344	WEEKLY MAT SERVICE: 1/31/25	08-30-4215 30.00	01/31/2025	30.00
4220422969	Cintas Corporation #344	WEEKLY MAT SERVICE: 2/7/25	08-30-4215 27.30	02/07/2025	27.30
Total Cintas Corporation #344:					83.59
<b>Comcast Cable</b>					
0367494-FEB25	Comcast Cable	CABLE: 2/3/25-3/2/25	01-14-4316 103.98	01/27/2025	103.98
Total Comcast Cable:					103.98
<b>Computype, Inc.</b>					
704005	COMPUTYPE, INC.	CALL LABEL SUPPLIES	01-12-4371 100.62 01-26-4518 15.77	01/10/2025	116.39
Total Computype, Inc.:					116.39
<b>CONSTANCE L. MARTIN</b>					
CLM022725	CONSTANCE L. MARTIN	PROGRAM - HIDDEN MESSAGES IN NEGRO SPIRITUALS - 2/27/25	01-24-4571 404.60	08/27/2024	404.60
Total CONSTANCE L. MARTIN:					404.60
<b>Costco</b>					
N8770-FEB25	Costco	PROGRAM SUPPLIES	01-24-4353 70.71 01-24-4353 28.02 01-24-4353 11.18	01/31/2025	109.91
Total Costco:					109.91
<b>Covers Unlimited Corp.</b>					

FOUNTAINDALE PUBLIC LIBRARY DISTRICT  
 BILLS PAYABLES REPORT  
 FEBRUARY 20, 2025

Invoice Number	Vendor Name	Description	Distributions\Amounts	Invoice Date	Inv Amt
<b>Covers Unlimited Corp.</b>					
20250113D	Covers Unlimited Corp.	REUPHOLSTER MULTIPLE CHAIRS	01-30-4391 6,368.70 01-30-4391 600.00	01/13/2025	6,968.70
Total Covers Unlimited Corp.:					6,968.70
<b>CRIMSON MULTIMEDIA DISTRIBUTION, INC.</b>					
018345	CRIMSON MULTIMEDIA DISTRIBUTION, INC.	YOUNG ADULT VIDEO GAMES	01-26-4563 146.32	12/12/2024	146.32
018346	CRIMSON MULTIMEDIA DISTRIBUTION, INC.	JUVENILE VIDEO GAMES	01-29-4564 50.00	12/12/2024	50.00
018347	CRIMSON MULTIMEDIA DISTRIBUTION, INC.	JUVENILE VIDEO GAMES	01-26-4564 50.00	12/12/2024	50.00
018348	CRIMSON MULTIMEDIA DISTRIBUTION, INC.	YOUNG ADULT VIDEO GAMES	01-26-4563 30.00	12/12/2024	30.00
018349	CRIMSON MULTIMEDIA DISTRIBUTION, INC.	YOUNG ADULT VIDEO GAMES	01-26-4563 103.29	12/12/2024	103.29
018350	CRIMSON MULTIMEDIA DISTRIBUTION, INC.	YOUNG ADULT VIDEO GAMES	01-26-4563 60.00	12/12/2024	60.00
018351	CRIMSON MULTIMEDIA DISTRIBUTION, INC.	YOUNG ADULT VIDEO GAMES	01-26-4563 60.00	12/12/2024	60.00
018484	CRIMSON MULTIMEDIA DISTRIBUTION, INC.	YOUNG ADULT VIDEO GAMES	01-26-4563 186.32	12/18/2024	186.32
018485	CRIMSON MULTIMEDIA DISTRIBUTION, INC.	ADULT VIDEO GAMES	01-26-4565 70.00	12/18/2024	70.00
018486	CRIMSON MULTIMEDIA DISTRIBUTION, INC.	ADULT VIDEO GAMES	01-26-4565 50.00	12/18/2024	50.00
018487	CRIMSON MULTIMEDIA DISTRIBUTION, INC.	YOUNG ADULT VIDEO GAMES	01-26-4563 50.00	12/18/2024	50.00
018488	CRIMSON MULTIMEDIA DISTRIBUTION, INC.	YOUNG ADULT VIDEO GAMES	01-26-4563 61.22	12/18/2024	61.22
018638	CRIMSON MULTIMEDIA DISTRIBUTION, INC.	JUVENILE VIDEO GAMES	01-26-4564 126.72	01/14/2025	126.72
018639	CRIMSON MULTIMEDIA DISTRIBUTION, INC.	ADULT VIDEO GAMES	01-26-4565 50.00	01/14/2025	50.00
018640	CRIMSON MULTIMEDIA DISTRIBUTION, INC.	YOUNG ADULT VIDEO GAMES	01-26-4563 60.00	01/14/2025	60.00
018641	CRIMSON MULTIMEDIA DISTRIBUTION, INC.	JUVENILE VIDEO GAMES	01-26-4564 30.00	01/14/2025	30.00
018642	CRIMSON MULTIMEDIA DISTRIBUTION, INC.	JUVENILE VIDEO GAMES	01-26-4564 30.00	01/14/2025	30.00
018643	CRIMSON MULTIMEDIA DISTRIBUTION, INC.	JUVENILE VIDEO GAMES	01-26-4564 60.00	01/14/2025	60.00
018644	CRIMSON MULTIMEDIA DISTRIBUTION, INC.	ADULT VIDEO GAMES	01-26-4565 36.39	01/14/2025	36.39
018645	CRIMSON MULTIMEDIA DISTRIBUTION, INC.	YOUNG ADULT VIDEO GAMES	01-26-4563 60.00	01/14/2025	60.00
018646	CRIMSON MULTIMEDIA DISTRIBUTION, INC.	YOUNG ADULT VIDEO GAMES	01-26-4563 60.00	01/14/2025	60.00
018740	CRIMSON MULTIMEDIA DISTRIBUTION, INC.	JUVENILE VIDEO GAMES	01-26-4564 227.42	01/21/2025	227.42
018741	CRIMSON MULTIMEDIA DISTRIBUTION, INC.	JUVENILE VIDEO GAMES	01-26-4564 60.00	01/21/2025	60.00
018742	CRIMSON MULTIMEDIA DISTRIBUTION, INC.	ADULT VIDEO GAMES	01-26-4565 60.00	01/21/2025	60.00

FOUNTAINDALE PUBLIC LIBRARY DISTRICT  
 BILLS PAYABLES REPORT  
 FEBRUARY 20, 2025

Invoice Number	Vendor Name	Description	Distributions\Amounts	Invoice Date	Inv Amt
<b>CRIMSON MULTIMEDIA DISTRIBUTION, INC.</b>					
018743	CRIMSON MULTIMEDIA DISTRIBUTION, INC.	YOUNG ADULT VIDEO GAMES	01-26-4563 60.00	01/21/2025	60.00
018744	CRIMSON MULTIMEDIA DISTRIBUTION, INC.	JUVENILE VIDEO GAMES	01-26-4564 163.36	01/21/2025	163.36
018745	CRIMSON MULTIMEDIA DISTRIBUTION, INC.	YOUNG ADULT VIDEO GAMES	01-26-4563 100.00	01/21/2025	100.00
018746	CRIMSON MULTIMEDIA DISTRIBUTION, INC.	JUVENILE VIDEO GAMES	01-29-4564 121.02	01/21/2025	121.02
018840	CRIMSON MULTIMEDIA DISTRIBUTION, INC.	JUVENILE VIDEO GAMES	01-29-4564 156.22	01/23/2025	156.22
018841	CRIMSON MULTIMEDIA DISTRIBUTION, INC.	JUVENILE VIDEO GAMES	01-26-4564 50.00	01/23/2025	50.00
018842	CRIMSON MULTIMEDIA DISTRIBUTION, INC.	JUVENILE VIDEO GAMES	01-26-4564 51.22	01/23/2025	51.22
018843	CRIMSON MULTIMEDIA DISTRIBUTION, INC.	JUVENILE VIDEO GAMES	01-26-4564 50.00	01/23/2025	50.00
018931	CRIMSON MULTIMEDIA DISTRIBUTION, INC.	YOUNG ADULT VIDEO GAMES	01-26-4563 106.44	01/27/2025	106.44
018932	CRIMSON MULTIMEDIA DISTRIBUTION, INC.	YOUNG ADULT VIDEO GAMES	01-26-4563 45.00	01/27/2025	45.00
018933	CRIMSON MULTIMEDIA DISTRIBUTION, INC.	YOUNG ADULT VIDEO GAMES	01-26-4563 45.00	01/27/2025	45.00
018934	CRIMSON MULTIMEDIA DISTRIBUTION, INC.	ADULT VIDEO GAMES	01-26-4565 30.00	01/29/2025	30.00
018935	CRIMSON MULTIMEDIA DISTRIBUTION, INC.	JUVENILE VIDEO GAMES	01-29-4564 122.71	01/27/2025	122.71
018936	CRIMSON MULTIMEDIA DISTRIBUTION, INC.	YOUNG ADULT VIDEO GAMES	01-26-4563 50.00	01/29/2025	50.00
018937	CRIMSON MULTIMEDIA DISTRIBUTION, INC.	ADULT VIDEO GAMES	01-26-4565 91.14	01/29/2025	91.14
Total CRIMSON MULTIMEDIA DISTRIBUTION, INC.:					3,019.79
<b>CRUNCHYROLL</b>					
P9444-FEB25	CRUNCHYROLL	1/8 OUTREACH ROKU MONTHLY SUBSCRIPTION	01-26-4523 11.99	01/31/2025	11.99
P9444-FEB25	CRUNCHYROLL	1/8 OUTREACH ROKU MONTHLY SUBSCRIPTION	01-26-4523 11.99	01/31/2025	11.99
T7780-FEB25	CRUNCHYROLL	1/8 OUTREACH ROKU MONTHLY SUBSCRIPTION	01-26-4523 11.99	01/31/2025	11.99
T7780-FEB25	CRUNCHYROLL	1/8 OUTREACH ROKU MONTHLY SUBSCRIPTION	01-26-4523 11.99	01/31/2025	11.99
T7780-FEB25	CRUNCHYROLL	1/8 OUTREACH ROKU MONTHLY SUBSCRIPTION	01-26-4523 11.99	01/31/2025	11.99
T7780-FEB25	CRUNCHYROLL	1/8 OUTREACH ROKU MONTHLY SUBSCRIPTION	01-26-4523 11.99	01/31/2025	11.99
T7780-FEB25	CRUNCHYROLL	1/8 OUTREACH ROKU MONTHLY SUBSCRIPTION	01-26-4523 11.99	01/31/2025	11.99
T7780-FEB25	CRUNCHYROLL	1/8 OUTREACH ROKU MONTHLY SUBSCRIPTION	01-26-4523 11.99	01/31/2025	11.99
Total CRUNCHYROLL:					95.92
<b>Culligan Bolingbrook, IL</b>					
0164026	Culligan Bolingbrook, IL	SOLAR SALT: DEC. 2024	08-30-4215 173.74	12/31/2024	173.74
0166071	Culligan Bolingbrook, IL	SOLAR SALT: JAN. 2025	08-30-4215 173.74	01/31/2025	173.74

FOUNTAINDALE PUBLIC LIBRARY DISTRICT  
 BILLS PAYABLES REPORT  
 FEBRUARY 20, 2025

Invoice Number	Vendor Name	Description	Distributions\Amounts	Invoice Date	Inv Amt
<b>Culligan Bolingbrook, IL</b>					
Total Culligan Bolingbrook, IL:					347.48
<b>CUTTING EDGE DOCUMENT DESTRUCTION</b>					
M33748	CUTTING EDGE DOCUMENT DESTRUCTION	RECORDS SHRED: 1/8/25	08-30-4215 30.00	01/08/2025	30.00
Total CUTTING EDGE DOCUMENT DESTRUCTION:					30.00
<b>Daily Southtown</b>					
74033238	Daily Southtown	PERIODICALS	01-26-4511 1,930.99	12/24/2024	1,930.99
Total Daily Southtown:					1,930.99
<b>Dale Kaczmarek</b>					
DK030825	Dale Kaczmarek	PROGRAM - SUBURBAN PARANORMAL SHOWCASE - 3/8/25	01-24-4571 100.00	01/23/2025	100.00
Total Dale Kaczmarek:					100.00
<b>Debtbook</b>					
DB2004585	Debtbook	ANNUAL GASB 96 SBITA MANAGEMENT	02-10-4251 8,400.00	02/01/2025	8,400.00
Total Debtbook:					8,400.00
<b>Demco, Inc.</b>					
7596452	Demco, Inc.	BOOK DISPLAY UNITS	01-10-4343 1,580.07 01-10-4343 7,998.00 01-10-4343 425.00	01/30/2025	10,003.07
7590212	DEMCO, INC.	PROCESSING & MENDING SUPPLIES	01-12-4371 311.56 01-12-4371 83.61 01-12-4371 104.94	01/16/2025	500.11
Total Demco, Inc.:					10,503.18
<b>DISNEY+</b>					
P9444-FEB25	DISNEY+	1/8 OUTREACH ROKU MONTHLY SUBSCRIPTION	01-26-4523 26.99	01/31/2025	26.99
P9444-FEB25	DISNEY+	1/8 OUTREACH ROKU MONTHLY SUBSCRIPTION	01-26-4523 26.99	01/31/2025	26.99
P9444-FEB25	DISNEY+	1/8 OUTREACH ROKU MONTHLY SUBSCRIPTION	01-26-4523 26.99	01/31/2025	26.99
Total DISNEY+:					80.97
<b>DOLLAR TREE</b>					
N8770-FEB25	DOLLAR TREE	PROGRAM SUPPLIES	01-27-4353 23.75	01/31/2025	23.75
Total DOLLAR TREE:					23.75
<b>DONUT DEN</b>					
M4566-FEB25	DONUT DEN	PLC STRATEGIC PLAN MEETING REFRESHMENTS	01-10-4715 37.14	01/31/2025	37.14
M4566-FEB25	DONUT DEN	DONUTS W/ DIRECTOR REFRESHMENTS: 1/21/25	01-10-4715 18.57	01/31/2025	18.57
Total DONUT DEN:					55.71
<b>Dynergy Energy Services</b>					
03000045001 1	Dynergy Energy Services	ELECTRICITY: 11/27/24- 12/30/24	01-30-4321 13,994.94	01/03/2025	13,994.94
Total Dynergy Energy Services:					13,994.94
<b>Elite Detailing Services, Inc.</b>					

FOUNTAINDALE PUBLIC LIBRARY DISTRICT  
 BILLS PAYABLES REPORT  
 FEBRUARY 20, 2025

Invoice Number	Vendor Name	Description	Distributions\Amounts	Invoice Date	Inv Amt
<b>Elite Detailing Services, Inc.</b>					
15435A	Elite Detailing Services, Inc.	BKM & TRANSIT CLEANING: 1/30/25	01-29-4235 200.00	01/30/2025	200.00
Total Elite Detailing Services, Inc.:					200.00
<b>FACEBOOK</b>					
N8770-FEB25	FACEBOOK	MONTHLY ADS	01-10-4731 3.71	01/31/2025	3.71
Total FACEBOOK:					3.71
<b>FAIR GAMES ENTERPRISES LLC</b>					
FGE031025	FAIR GAMES ENTERPRISES LLC	PROGRAM - MONDAY MORNING MAHJONG - 3/10/25	01-24-4571 100.00	01/31/2025	100.00
Total FAIR GAMES ENTERPRISES LLC:					100.00
<b>Filter Services Inc.</b>					
INV416208	FILTER SERVICES INC.	VARIOUS PLEATED FILTERS	01-30-4651 39.84 01-30-4651 13.44 01-30-4651 100.00	01/24/2025	153.28
INV416652	Filter Services Inc.	PLEATED & BOXED FILTER STOCK	01-30-4651 313.74 01-30-4651 73.92 01-30-4651 48.30 01-30-4651 27.48 01-30-4651 32.04 01-30-4651 870.21 01-30-4651 237.84 01-30-4651 118.92 01-30-4651 90.00	01/29/2025	1,812.45
Total Filter Services Inc.:					1,965.73
<b>Forward Space</b>					
843941	Forward Space	ADMIN CABINET TOP	08-30-4211 255.92	01/21/2025	255.92
844699	Forward Space	ATSD SIT/STAND DESK BASE	08-30-4211 570.00 08-30-4211 94.80 08-30-4211 625.00 08-30-4211 188.00	01/31/2025	1,477.80
Total Forward Space:					1,733.72
<b>Fun Express LLC</b>					
73578710501	Fun Express LLC	VARIOUS TEEN SUPPLIES	01-24-4353 47.97 01-24-4353 53.97 01-24-4353 102.36 01-24-4353 55.17 01-24-4353 55.17 01-24-4353 47.97 01-24-4353 95.97 01-24-4353 39.98	01/27/2025	498.56
73578759901	Fun Express LLC	JAN. 2025 PROGRAM SUPPLIES	01-24-4353 49.70 01-24-4353 43.14 01-24-4353 63.97 01-24-4353 47.94 01-24-4353 3.18	01/28/2025	207.93
Total Fun Express LLC:					706.49
<b>Gale/Cengage Learning</b>					
86074361	Gale/Cengage Learning	ADULT LARGE PRINT BOOKS	01-26-4543 74.22	12/18/2024	74.22
86149720	Gale/Cengage Learning	ADULT LARGE PRINT BOOKS	01-26-4543 28.79	01/07/2025	28.79
86172697	Gale/Cengage Learning	ADULT LARGE PRINT BOOKS	01-26-4543 29.59	01/08/2025	29.59



FOUNTAINDALE PUBLIC LIBRARY DISTRICT  
 BILLS PAYABLES REPORT  
 FEBRUARY 20, 2025

Invoice Number	Vendor Name	Description	Distributions\Amounts	Invoice Date	Inv Amt
<b>Gale/Cengage Learning</b>					
86173414	Gale/Cengage Learning	ADULT LARGE PRINT BOOKS	01-26-4543 98.37	01/08/2025	98.37
86190836	Gale/Cengage Learning	ADULT LARGE PRINT BOOKS	01-26-4543 26.39	01/09/2025	26.39
86471934	Gale/Cengage Learning	ADULT LARGE PRINT BOOKS	01-26-4543 74.22	01/22/2025	74.22
86472432	Gale/Cengage Learning	ADULT LARGE PRINT BOOKS	01-26-4543 125.55	01/22/2025	125.55
86665430	Gale/Cengage Learning	ADULT LARGE PRINT BOOKS	01-26-4543 52.40	01/30/2025	52.40
Total Gale/Cengage Learning:					509.53
<b>Grasso Graphics, Inc.</b>					
33389	Grasso Graphics, Inc.	REFILL RACK CARDS	01-10-4256 540.59	01/31/2025	540.59
Total Grasso Graphics, Inc.:					540.59
<b>Graybar</b>					
9340444862	Graybar	MEETING RM D DIMMING DRIVERS	08-30-4357 234.54	01/13/2025	234.54
Total Graybar:					234.54
<b>HAUNTED GALENA TOUR COMPANY INC.</b>					
HGTC030825	HAUNTED GALENA TOUR COMPANY INC.	PROGRAM - SUBURBAN PARANORMAL SHOWCASE - 3/8/25	01-24-4571 100.00	01/31/2025	100.00
Total HAUNTED GALENA TOUR COMPANY INC.:					100.00
<b>H-O-H Water Technology</b>					
692428	H-O-H Water Technology	QUARTERLY WATER TREATMENT: JAN, FEB, MARCH 2025	08-30-4215 292.14	01/08/2025	292.14
Total H-O-H Water Technology:					292.14
<b>HULU</b>					
K6602-FEB25	HULU	2/12 ROKU MONTHLY SUBSCRIPTIONS	01-26-4523 18.99	01/31/2025	18.99
K6602-FEB25	HULU	2/12 ROKU MONTHLY SUBSCRIPTIONS	01-26-4523 18.99	01/31/2025	18.99
K6602-FEB25	HULU	2/12 ROKU MONTHLY SUBSCRIPTIONS	01-26-4523 18.99	01/31/2025	18.99
K6602-FEB25	HULU	2/12 ADDITIONAL ROKU MONTHLY SUBSCRIPTIONS	01-26-4523 18.99	01/31/2025	18.99
K6602-FEB25	HULU	2/12 ADDITIONAL ROKU MONTHLY SUBSCRIPTIONS	01-26-4523 18.99	01/31/2025	18.99
K6602-FEB25	HULU	2/12 ADDITIONAL ROKU MONTHLY SUBSCRIPTIONS	01-26-4523 18.99	01/31/2025	18.99
P9444-FEB25	HULU	1/8 OUTREACH ROKU MONTHLY BUNDLE SUBSCRIPTION	01-26-4523 26.99	01/31/2025	26.99
P9444-FEB25	HULU	1/8 OUTREACH ROKU MONTHLY SUBSCRIPTION	01-26-4523 18.99	01/31/2025	18.99
P9444-FEB25	HULU	1/8 OUTREACH ROKU MONTHLY SUBSCRIPTION	01-26-4523 18.99	01/31/2025	18.99
P9444-FEB25	HULU	1/8 OUTREACH ROKU MONTHLY SUBSCRIPTION	01-26-4523 18.99	01/31/2025	18.99
N8770-FEB25	HULU	2/12 ADDITIONAL ROKU MONTHLY SUBSCRIPTIONS	01-26-4523 18.99	01/31/2025	18.99
M4566-FEB25	HULU	2/12 ADDITIONAL ROKU MONTHLY SUBSCRIPTIONS	01-26-4523 18.99	01/31/2025	18.99
T7780-FEB25	HULU	2/12 ROKU MONTHLY SUBSCRIPTIONS	01-26-4523 18.99	01/31/2025	18.99
T7780-FEB25	HULU	2/12 ROKU MONTHLY SUBSCRIPTIONS	01-26-4523 18.99	01/31/2025	18.99

FOUNTAINDALE PUBLIC LIBRARY DISTRICT  
 BILLS PAYABLES REPORT  
 FEBRUARY 20, 2025

Invoice Number	Vendor Name	Description	Distributions\Amounts	Invoice Date	Inv Amt
<b>HULU</b>					
T7780-FEB25	HULU	2/12 ROKU MONTHLY SUBSCRIPTIONS	01-26-4523 18.99	01/31/2025	18.99
T7780-FEB25	HULU	2/12 ADDITIONAL ROKU MONTHLY SUBSCRIPTIONS	01-26-4523 18.99	01/31/2025	18.99
T7780-FEB25	HULU	1/8 OUTREACH ROKU MONTHLY SUBSCRIPTIONS	01-26-4523 18.99	01/31/2025	18.99
Total HULU:					330.83
<b>ILLINOIS AMERICAN WATER</b>					
1025-210003089465	Illinois American Water	FIRE PROTECTION: 1/22/25-2/19/25	01-30-4331 54.47	01/22/2025	54.47
Total ILLINOIS AMERICAN WATER:					54.47
<b>ILLINOIS AMERICAN WATER/BOLINGBROOK</b>					
1025-210003088318	Illinois American Water/Bolingbrook	WATER & SEWER: 12/19/24-1/21/25	01-30-4331 1,011.18	01/23/2025	1,011.18
Total ILLINOIS AMERICAN WATER/BOLINGBROOK:					1,011.18
<b>ILLINOIS GOVERNMENT FINANCE OFFICERS ASSOCIATION</b>					
2025DUES	ILLINOIS GOVERNMENT FINANCE OFFICERS ASSOCIATION	NGUYEN, SCHILLER, CERVANTES: 2025 DUES	01-10-4161 100.00 01-10-4161 100.00 01-10-4161 400.00	02/03/2025	600.00
Total ILLINOIS GOVERNMENT FINANCE OFFICERS ASSOCIATION:					600.00
<b>ILLINOIS LIBRARY ASSOCIATION</b>					
302048	Illinois Library Association	BERMEJO MEMBERSHIP: 4/1/25-3/31/26	01-16-4161 75.00	01/09/2025	75.00
302342	Illinois Library Association	DOLLEY MEMBERSHIP: 4/1/25-3/31/26	01-10-4161 100.00	01/06/2025	100.00
302345	Illinois Library Association	SISKA MEMBERSHIP: 4/1/25-3/31/26	01-16-4161 75.00	01/09/2025	75.00
Total ILLINOIS LIBRARY ASSOCIATION:					250.00
<b>Ingram Library Services</b>					
85726374	INGRAM LIBRARY SERVICES	LIBRARY COLLECTION MATERIALS	01-26-4544 81.18 01-26-4546 264.12 01-26-4548 117.68 01-29-4544 19.48 01-29-4546 31.62 01-29-4548 9.74 01-26-4518 38.05	01/02/2025	561.87
85743735	Ingram Library Services	LIBRARY COLLECTION MATERIALS	01-26-4544 132.75 01-26-4545 22.48 01-26-4546 111.42 01-26-4548 43.41 01-26-4518 29.62	01/03/2025	339.68

FOUNTAINDALE PUBLIC LIBRARY DISTRICT  
 BILLS PAYABLES REPORT  
 FEBRUARY 20, 2025

Invoice Number	Vendor Name	Description	Distributions\Amounts	Invoice Date	Inv Amt
<b>Ingram Library Services</b>					
85809426	Ingram Library Services	LIBRARY COLLECTION MATERIALS	01-26-4544 433.94 01-26-4545 68.04 01-26-4546 415.41 01-26-4548 185.35 01-29-4544 40.12 01-29-4546 96.11 01-29-4548 10.73 01-26-4526 107.29 01-29-4526 43.57 01-26-4518 115.37	01/07/2025	1,515.93
85809427	Ingram Library Services	LIBRARY COLLECTION MATERIALS	01-26-4544 354.75 01-26-4546 400.84 01-26-4548 19.08 01-29-4544 76.41 01-29-4546 97.31 01-26-4518 63.76	01/07/2025	1,012.15
85865857	Ingram Library Services	LIBRARY COLLECTION MATERIALS	01-26-4545 21.58 01-26-4546 635.01 01-26-4548 100.83 01-29-4546 231.62 01-26-4526 28.46 01-29-4526 14.23 01-26-4518 16.35	01/08/2025	1,048.08
85878704	Ingram Library Services	LIBRARY COLLECTION MATERIALS	01-26-4544 450.26 01-26-4546 709.70 01-26-4548 136.09 01-26-4549 14.12 01-29-4544 47.82 01-29-4546 154.89 01-29-4548 11.29 01-26-4518 105.02	01/09/2025	1,629.19
85911998	Ingram Library Services	LIBRARY COLLECTION MATERIALS	01-26-4544 81.83 01-26-4546 53.07 01-26-4548 31.11 01-29-4544 16.72 01-29-4546 19.90 01-26-4518 17.10	01/10/2025	219.73
85936469	Ingram Library Services	LIBRARY COLLECTION MATERIALS	01-26-4544 341.05 01-26-4546 21.46 01-29-4544 5.19 01-26-4518 13.22	01/13/2025	380.92
85948341	Ingram Library Services	LIBRARY COLLECTION MATERIALS	01-26-4544 99.61 01-26-4545 49.16 01-26-4546 22.54 01-26-4548 31.48 01-26-4518 16.35	01/13/2025	219.14
85974756	Ingram Library Services	LIBRARY COLLECTION MATERIALS	01-26-4544 83.50 01-26-4546 83.61 01-26-4548 52.22 01-29-4544 10.16 01-29-4546 14.98 01-26-4518 19.99	01/14/2025	264.46

FOUNTAINDALE PUBLIC LIBRARY DISTRICT  
 BILLS PAYABLES REPORT  
 FEBRUARY 20, 2025

Invoice Number	Vendor Name	Description	Distributions\Amounts	Invoice Date	Inv Amt
<b>Ingram Library Services</b>					
85974757	Ingram Library Services	LIBRARY COLLECTION MATERIALS	01-26-4544 258.20 01-26-4546 110.86 01-26-4548 76.62 01-29-4544 11.29 01-29-4546 17.28 01-26-4518 18.92	01/14/2025	493.17
86011273	Ingram Library Services	LIBRARY COLLECTION MATERIALS	01-26-4544 124.99 01-26-4546 76.23 01-26-4548 40.16 01-29-4544 10.49 01-26-4526 237.77 01-26-4518 16.03	01/15/2025	505.67
86030701	Ingram Library Services	LIBRARY COLLECTION MATERIALS	01-26-4544 22.48 01-26-4546 65.35 01-26-4548 311.46 01-29-4546 8.98 01-26-4526 16.48 01-26-4518 21.38	01/15/2025	446.13
86066378	Ingram Library Services	LIBRARY COLLECTION MATERIALS	01-26-4544 105.64 01-26-4546 74.76 01-26-4548 52.10 01-26-4526 213.13 01-26-4518 5.06	01/16/2025	450.69
85454835	Ingram Library Services	LIBRARY COLLECTION MATERIALS	01-26-4544 25.46 01-26-4546 42.92 01-26-4548 25.75 01-26-4526 49.14 01-26-4518 19.40	12/18/2024	162.67
85483717	Ingram Library Services	LIBRARY COLLECTION MATERIALS	01-26-4544 67.38 01-26-4546 62.65 01-26-4548 7.79 01-29-4544 8.44 01-29-4546 8.24 01-26-4518 9.02	12/19/2024	163.52
85511689	Ingram Library Services	LIBRARY COLLECTION MATERIALS	01-26-4544 114.86 01-26-4545 10.16 01-26-4546 313.80 01-26-4548 58.80 01-26-4549 16.89 01-29-4544 14.98 01-26-4518 50.73	12/20/2024	580.22
85553554	Ingram Library Services	LIBRARY COLLECTION MATERIALS	01-26-4544 114.92 01-26-4546 15.72 01-26-4548 20.08 01-26-4518 35.96	12/23/2024	186.68
85545557	Ingram Library Services	LIBRARY COLLECTION MATERIALS	01-26-4544 37.38 01-26-4546 31.46 01-26-4548 10.14 01-26-4526 30.09 01-26-4518 13.14	12/23/2024	122.21
85545558	Ingram Library Services	LIBRARY COLLECTION MATERIALS	01-26-4544 253.22 01-26-4545 11.29 01-26-4546 74.74 01-26-4548 39.30 01-29-4544 46.78 01-29-4546 10.73 01-26-4518 34.33	12/23/2024	470.39

FOUNTAINDALE PUBLIC LIBRARY DISTRICT  
 BILLS PAYABLES REPORT  
 FEBRUARY 20, 2025

Invoice Number	Vendor Name	Description	Distributions\Amounts	Invoice Date	Inv Amt
<b>Ingram Library Services</b>					
85599477	Ingram Library Services	LIBRARY COLLECTION MATERIALS	01-26-4544 125.43 01-26-4546 469.60 01-26-4548 32.48 01-29-4544 5.19 01-29-4546 10.16 01-26-4518 41.34	12/26/2024	684.20
85610262	Ingram Library Services	LIBRARY COLLECTION MATERIALS	01-26-4544 44.94 01-26-4546 61.90 01-26-4548 18.83 01-29-4544 9.09 01-29-4546 32.28 01-26-4518 21.54	12/26/2024	188.58
85619525	Ingram Library Services	LIBRARY COLLECTION MATERIALS	01-26-4544 215.61 01-26-4546 272.11 01-26-4548 8.44 01-29-4544 249.76 01-29-4546 53.82 01-26-4518 44.47	12/27/2024	844.21
85657003	Ingram Library Services	LIBRARY COLLECTION MATERIALS	01-26-4544 650.52 01-26-4545 10.16 01-26-4546 351.52 01-26-4548 19.49 01-29-4544 13.48 01-29-4546 123.65 01-29-4548 21.46 01-26-4526 151.99 01-29-4526 28.70 01-26-4518 54.45	12/30/2024	1,425.42
85668746	Ingram Library Services	LIBRARY COLLECTION MATERIALS	01-26-4544 30.50 01-26-4546 20.28 01-26-4548 117.31 01-26-4526 100.80 01-26-4518 11.08	12/30/2024	279.97
85694120	Ingram Library Services	LIBRARY COLLECTION MATERIALS	01-26-4544 366.53 01-26-4546 380.98 01-29-4546 163.33 01-26-4518 12.15	12/31/2024	922.99
85694121	Ingram Library Services	LIBRARY COLLECTION MATERIALS	01-26-4544 224.48 01-26-4546 585.61 01-26-4548 48.70 01-29-4544 61.76 01-29-4546 46.64 01-26-4526 104.20 01-26-4518 16.27	12/31/2024	1,087.66
85595161	Ingram Library Services	CREDITED JUVENILE EASY BOOKS	01-26-4546 (34.12) 01-26-4518 (1.98)	12/24/2024	(36.10)
86100179	Ingram Library Services	CREDITED YOUNG ADULT FICTION BOOKS	01-26-4548 (9.85)	01/17/2025	(9.85)
86120957	Ingram Library Services	LIBRARY COLLECTION MATERIALS	01-26-4544 470.42 01-26-4546 227.20 01-26-4548 307.65 01-29-4544 43.37 01-29-4546 68.38 01-29-4548 10.16 01-26-4526 90.80 01-26-4518 79.12	01/21/2025	1,297.10

FOUNTAINDALE PUBLIC LIBRARY DISTRICT  
 BILLS PAYABLES REPORT  
 FEBRUARY 20, 2025

Invoice Number	Vendor Name	Description	Distributions\Amounts	Invoice Date	Inv Amt
<b>Ingram Library Services</b>					
86189162	Ingram Library Services	LIBRARY COLLECTION MATERIALS	01-26-4544 77.48 01-26-4546 94.86 01-26-4548 83.57 01-29-4544 5.99 01-29-4548 22.02 01-26-4526 10.77 01-26-4518 35.00	01/23/2025	329.69
8622540	Ingram Library Services	LIBRARY COLLECTION MATERIALS	01-26-4544 22.48 01-26-4546 359.86 01-26-4548 33.11 01-29-4544 11.24 01-29-4546 18.69 01-26-4526 56.28 01-29-4526 10.73 01-26-4518 30.29	01/24/2025	542.68
86258167	Ingram Library Services	LIBRARY COLLECTION MATERIALS	01-26-4546 282.44 01-26-4548 184.01 01-29-4546 18.69 01-26-4526 9.58 01-26-4518 46.29	01/27/2025	541.01
86285521	Ingram Library Services	LIBRARY COLLECTION MATERIALS	01-26-4544 98.60 01-26-4546 42.92 01-26-4548 100.67 01-26-4518 39.52	01/28/2025	281.71
86316540	Ingram Library Services	LIBRARY COLLECTION MATERIALS	01-26-4544 299.40 01-26-4546 117.83 01-26-4548 34.58 01-29-4548 12.42 01-26-4526 32.28 01-26-4518 68.36	01/29/2025	564.87
86332551	Ingram Library Services	LIBRARY COLLECTION MATERIALS	01-26-4541 9.59 01-26-4546 101.54 01-26-4548 12.99 01-26-4518 9.10	01/29/2025	133.22
86345797	Ingram Library Services	LIBRARY COLLECTION MATERIALS	01-26-4544 151.38 01-26-4546 276.34 01-26-4548 73.85 01-29-4544 20.89 01-29-4546 11.29 01-29-4548 20.89 01-26-4518 52.74	01/30/2025	607.38
86372660	Ingram Library Services	LIBRARY COLLECTION MATERIALS	01-26-4544 52.32 01-26-4546 60.42 01-29-4544 163.96 01-29-4546 10.16 01-26-4518 25.26	01/31/2025	312.12
86397984	Ingram Library Services	LIBRARY COLLECTION MATERIALS	01-26-4544 210.43 01-26-4545 10.16 01-26-4546 328.89 01-26-4548 81.44 01-29-4544 10.16 01-29-4546 9.60 01-26-4526 10.77 01-26-4518 48.94	02/03/2025	710.39

FOUNTAINDALE PUBLIC LIBRARY DISTRICT  
 BILLS PAYABLES REPORT  
 FEBRUARY 20, 2025

Invoice Number	Vendor Name	Description	Distributions\Amounts	Invoice Date	Inv Amt
<b>Ingram Library Services</b>					
86423702	Ingram Library Services	LIBRARY COLLECTION MATERIALS	01-26-4544 209.69 01-26-4546 128.70 01-26-4548 21.05 01-29-4544 10.73 01-26-4518 32.11	02/04/2025	402.28
86416037	Ingram Library Services	CREDITED BOOKS	01-26-4545 (11.39) 01-29-4548 (10.73) 01-26-4518 (3.05)	02/03/2025	(25.17)
Total Ingram Library Services:					21,856.86
<b>ITSavvy LLC</b>					
01546210	ITSavvy LLC	REDSKY E911 SERVICE ANNUAL RENEWAL	01-14-4631 1,218.00	01/22/2025	1,218.00
01546254	ITSavvy LLC	CISCO ANYCONNECT PLUS VPN LICENSE RENEWAL	01-14-4233 93.50	01/22/2025	93.50
01546513	ITSavvy LLC	CISCO SERVICE CONTRACT RENEWALS	01-14-4233 3,252.24 01-14-4233 129.64 01-14-4233 10.90 01-14-4233 8,059.44 01-14-4233 3,394.08 01-14-4233 683.20	01/23/2025	15,529.50
01546878	ITSavvy LLC	CISCO CHARGER POWER SUPPLY	01-14-4641 514.30	01/27/2025	514.30
Total ITSavvy LLC:					17,355.30
<b>Jacqueline Kohn</b>					
JK021025	Jacqueline Kohn	OUTREACH MILEAGE: 12/2/24-12/26/24	01-10-4171 51.99	02/10/2025	51.99
Total Jacqueline Kohn:					51.99
<b>Jennifer Fredrick</b>					
JF021125	Jennifer Fredrick	TUITION REIMBURSE: 2 FALL 2024 COURSES	01-10-4151 3,332.02	02/11/2025	3,332.02
Total Jennifer Fredrick:					3,332.02
<b>JIMMY JOHN'S</b>					
N8770-FEB25	JIMMY JOHN'S	SENIOR SOCIAL LUNCHES	01-24-4353 125.97 01-24-4353 29.16	01/31/2025	155.13
Total JIMMY JOHN'S:					155.13
<b>Johnson Controls Fire Protection</b>					
24517916	Johnson Controls Fire Protection	ANNUAL FIRE PROTECTION AGREEMENT	08-30-4215 14,930.00	01/03/2025	14,930.00
Total Johnson Controls Fire Protection:					14,930.00
<b>Juanita Lennon</b>					
JL013025	Juanita Lennon	REIMBURSE: VARIOUS MEETING REFRESHMENTS	01-10-4715 32.50 01-10-4715 14.43 01-16-4355 25.43 01-10-4715 16.27	01/30/2025	88.63
Total Juanita Lennon:					88.63
<b>KATHI KRESOL</b>					
KK030825	KATHI KRESOL	PROGRAM - SUBURBAN PARANORMAL SHOWCASE - 3/8/25	01-24-4571 100.00	01/28/2025	100.00
Total KATHI KRESOL:					100.00

**FOUNTAINDALE PUBLIC LIBRARY DISTRICT**  
**BILLS PAYABLES REPORT**  
**FEBRUARY 20, 2025**

Invoice Number	Vendor Name	Description	Distributions\Amounts	Invoice Date	Inv Amt
<b>KATHLEEN O'LEARY</b>					
KOL031725	KATHLEEN O'LEARY	PROGRAM - IRISH GENEALOGY WORKSHOP - 3/17/25	01-24-4571 175.00	01/28/2025	175.00
Total KATHLEEN O'LEARY:					175.00
<b>KONICA MINOLTA BUSINESS SOLUTIONS</b>					
9010262155	KONICA MINOLTA BUSINESS SOLUTIONS	MAINTENANCE: 12/1/24-12/31/24	01-14-4234 552.20	12/31/2024	552.20
9010267887	KONICA MINOLTA BUSINESS SOLUTIONS	MAINTENANCE: 1/1/25-1/20/25	01-14-4234 264.27	01/01/2025	264.27
Total KONICA MINOLTA BUSINESS SOLUTIONS:					816.47
<b>Kramer Tree Specialists, Inc.</b>					
21708-2	Kramer Tree Specialists, Inc.	HOLIDAY LIGHTS REMOVAL	01-30-4392 295.00	02/06/2025	295.00
Total Kramer Tree Specialists, Inc.:					295.00
<b>Lauterbach &amp; Amen, LLP</b>					
97876	Lauterbach & Amen, LLP	QUARTERLY RECORDS MANAGEMENT: OCT. - DEC. 2024	01-10-4253 1,333.33	11/13/2024	1,333.33
Total Lauterbach & Amen, LLP:					1,333.33
<b>LIBRARIA</b>					
254248	LIBRARIA	JUVENILE NONFICTION BOOKS	01-26-4545 19.99	12/16/2024	19.99
254249	LIBRARIA	JUVENILE NONFICTION BOOKS	01-26-4545 29.99	12/16/2024	29.99
254354	LIBRARIA	JUVENILE NONFICTION BOOKS	01-26-4545 14.99	12/19/2024	14.99
254403	LIBRARIA	JUVENILE NONFICTION BOOKS	01-26-4545 17.99	12/19/2024	17.99
254474	LIBRARIA	JUVENILE NONFICTION BOOKS	01-29-4545 21.98	12/26/2024	21.98
254476	LIBRARIA	JUVENILE NONFICTION BOOKS	01-26-4545 95.95	12/26/2024	95.95
254515	LIBRARIA	JUVENILE NONFICTION BOOKS	01-26-4545 139.81	12/27/2024	139.81
254551	LIBRARIA	YOUNG ADULT NONFICTION BOOKS	01-26-4549 22.99	12/27/2024	22.99
254582	LIBRARIA	JUVENILE NONFICTION BOOKS	01-26-4545 103.95	12/30/2024	103.95
254586	LIBRARIA	JUVENILE NONFICTION BOOKS	01-26-4545 9.99	12/30/2024	9.99
254587	LIBRARIA	JUVENILE NONFICTION BOOKS	01-26-4545 31.98	12/30/2024	31.98
254600	LIBRARIA	JUVENILE NONFICTION BOOKS	01-26-4545 39.98	12/30/2024	39.98
254755	LIBRARIA	JUVENILE NONFICTION BOOKS	01-26-4545 33.98	01/03/2025	33.98
254756	LIBRARIA	YOUNG ADULT NONFICTION BOOKS	01-26-4549 22.99	01/03/2025	22.99
254791	LIBRARIA	JUVENILE NONFICTION BOOKS	01-26-4545 46.93	01/03/2025	46.93
254792	LIBRARIA	JUVENILE NONFICTION BOOKS	01-26-4545 112.90	01/03/2025	112.90
254793	LIBRARIA	YOUNG ADULT NONFICTION BOOKS	01-26-4549 19.99	01/03/2025	19.99
254794	LIBRARIA	JUVENILE NONFICTION BOOKS	01-29-4545 229.90	01/03/2025	229.90
254797	LIBRARIA	JUVENILE NONFICTION BOOKS	01-29-4545 16.99	01/03/2025	16.99
254798	LIBRARIA	JUVENILE NONFICTION BOOKS	01-29-4545 22.99	01/03/2025	22.99
254802	LIBRARIA	JUVENILE NONFICTION BOOKS	01-26-4545 459.80	01/03/2025	459.80
254830	LIBRARIA	JUVENILE NONFICTION BOOKS	01-26-4545 18.99	01/07/2025	18.99
254881	LIBRARIA	YOUNG ADULT NONFICTION BOOKS	01-26-4549 12.95	01/07/2025	12.95
254890	LIBRARIA	YOUNG ADULT NONFICTION BOOKS	01-26-4549 162.93	01/08/2025	162.93
254891	LIBRARIA	JUVENILE NONFICTION BOOKS	01-26-4545 260.60	01/08/2025	260.60
254955	LIBRARIA	JUVENILE NONFICTION BOOKS	01-26-4545 23.95	01/09/2025	23.95
254979	LIBRARIA	JUVENILE NONFICTION BOOKS	01-26-4545 18.99	01/10/2025	18.99
254980	LIBRARIA	JUVENILE NONFICTION BOOKS	01-29-4545 29.94	01/10/2025	29.94
254981	LIBRARIA	JUVENILE NONFICTION BOOKS	01-26-4545 44.85	01/10/2025	44.85
254987	LIBRARIA	JUVENILE NONFICTION BOOKS	01-26-4545 18.99	01/10/2025	18.99
255071	LIBRARIA	JUVENILE NONFICTION BOOKS	01-29-4545 24.99	01/14/2025	24.99



FOUNTAINDALE PUBLIC LIBRARY DISTRICT  
 BILLS PAYABLES REPORT  
 FEBRUARY 20, 2025

Invoice Number	Vendor Name	Description	Distributions\Amounts	Invoice Date	Inv Amt
<b>LIBRARIA</b>					
255095	LIBRARIA	YOUNG ADULT NONFICTION BOOKS	01-26-4549 105.27	01/14/2025	105.27
255133	LIBRARIA	JUVENILE NONFICTION BOOKS	01-26-4545 72.96	01/15/2025	72.96
255134	LIBRARIA	JUVENILE NONFICTION BOOKS	01-26-4545 17.99	01/15/2025	17.99
255135	LIBRARIA	JUVENILE NONFICTION BOOKS	01-26-4545 23.99	01/15/2025	23.99
255175	LIBRARIA	JUVENILE NONFICTION BOOKS	01-26-4545 18.95	01/15/2025	18.95
254991	LIBRARIA	JUVENILE NONFICTION BOOKS	01-26-4545 81.88	01/10/2025	81.88
255223	LIBRARIA	JUVENILE NONFICTION BOOKS	01-26-4545 59.97	01/17/2025	59.97
255224	LIBRARIA	JUVENILE NONFICTION BOOKS	01-29-4545 18.99	01/17/2025	18.99
255225	LIBRARIA	JUVENILE NONFICTION BOOKS	01-26-4545 48.93	01/17/2025	48.93
255275	LIBRARIA	JUVENILE NONFICTION BOOKS	01-26-4545 141.88	01/17/2025	141.88
255276	LIBRARIA	YOUNG ADULT NONFICTION BOOKS	01-26-4549 19.99	01/17/2025	19.99
255309	LIBRARIA	JUVENILE NONFICTION BOOKS	01-26-4545 47.98	01/20/2025	47.98
255464	LIBRARIA	YOUNG ADULT NONFICTION BOOKS	01-26-4549 46.90	01/23/2025	46.90
255469	LIBRARIA	JUVENILE NONFICTION BOOKS	01-26-4545 29.98	01/23/2025	29.98
255486	LIBRARIA	YOUNG ADULT NONFICTION BOOKS	01-26-4549 16.99	01/23/2025	16.99
255595	LIBRARIA	JUVENILE NONFICTION BOOKS	01-26-4545 127.95	01/27/2025	127.95
255596	LIBRARIA	JUVENILE NONFICTION BOOKS	01-29-4545 42.94	01/27/2025	42.94
255597	LIBRARIA	JUVENILE NONFICTION BOOKS	01-26-4545 38.98	01/27/2025	38.98
255598	LIBRARIA	YOUNG ADULT NONFICTION BOOKS	01-26-4549 19.99	01/27/2025	19.99
255599	LIBRARIA	JUVENILE NONFICTION BOOKS	01-26-4545 37.98	01/27/2025	37.98
255600	LIBRARIA	JUVENILE NONFICTION BOOKS	01-26-4545 55.89	01/27/2025	55.89
255703	LIBRARIA	YOUNG ADULT NONFICTION BOOKS	01-26-4549 22.99	01/30/2025	22.99
255704	LIBRARIA	JUVENILE NONFICTION BOOKS	01-26-4545 44.97	01/30/2025	44.97
255738	LIBRARIA	JUVENILE NONFICTION BOOKS	01-26-4545 639.75	01/30/2025	639.75
255767	LIBRARIA	JUVENILE NONFICTION BOOKS	01-29-4545 19.99	01/30/2025	19.99
255816	LIBRARIA	YOUNG ADULT NONFICTION BOOKS	01-26-4549 17.99	01/31/2025	17.99
255818	LIBRARIA	JUVENILE NONFICTION BOOKS	01-26-4545 311.11	01/31/2025	311.11
255817	LIBRARIA	JUVENILE NONFICTION BOOKS	01-26-4545 567.27	01/31/2025	567.27
255819	LIBRARIA	JUVENILE NONFICTION BOOKS	01-26-4545 64.88	01/31/2025	64.88
Total LIBRARIA:					4,898.57
<b>Lorena Y Carreno</b>					
LYC022525	Lorena Y Carreno	PROGRAM - ARTESANIAS EN ESPANOL - 2/25/25	01-24-4571 250.00	09/26/2024	250.00
LYC031825	Lorena Y Carreno	PROGRAM - ARTESANIAS EN ESPANOL - 3/18/25	01-24-4571 250.00	01/31/2025	250.00
Total Lorena Y Carreno:					500.00
<b>Lutron Services Co., Inc.</b>					
23842094	Lutron Services Co., Inc.	SUPPORT PLAN PLATINUM: 1/21/25-1/20/26	08-30-4215 5,391.26	01/21/2025	5,391.26
Total Lutron Services Co., Inc.:					5,391.26
<b>MAILCHIMP</b>					
N8770-FEB25	MAILCHIMP	MONTHLY SUBSCRIPTION	01-10-4731 75.00	01/31/2025	75.00
Total MAILCHIMP:					75.00
<b>MAX HBO MAX</b>					
T7780-FEB25	MAX	3/12 ROKU MONTHLY SUBSCRIPTIONS	01-26-4523 16.99	01/31/2025	16.99
T7780-FEB25	MAX	3/12 ROKU MONTHLY SUBSCRIPTIONS	01-26-4523 16.99	01/31/2025	16.99

FOUNTAINDALE PUBLIC LIBRARY DISTRICT  
 BILLS PAYABLES REPORT  
 FEBRUARY 20, 2025

Invoice Number	Vendor Name	Description	Distributions\Amounts	Invoice Date	Inv Amt
<b>MAX HBO MAX</b>					
T7780-FEB25	MAX	3/12 ROKU MONTHLY SUBSCRIPTIONS	01-26-4523 16.99	01/31/2025	16.99
T7780-FEB25	MAX	3/12 ROKU MONTHLY SUBSCRIPTIONS	01-26-4523 16.99	01/31/2025	16.99
T7780-FEB25	MAX	3/12 ADDITIONAL ROKU MONTHLY SUBSCRIPTIONS	01-26-4523 16.99	01/31/2025	16.99
T7780-FEB25	MAX	3/12 ADDITIONAL ROKU MONTHLY SUBSCRIPTIONS	01-26-4523 16.99	01/31/2025	16.99
T7780-FEB25	MAX	3/12 ADDITIONAL ROKU MONTHLY SUBSCRIPTIONS	01-26-4523 16.99	01/31/2025	16.99
T7780-FEB25	MAX	3/12 ADDITIONAL ROKU MONTHLY SUBSCRIPTIONS	01-26-4523 16.99	01/31/2025	16.99
Total MAX HBO MAX:					135.92
<b>MEIJER</b>					
N8770-FEB25	MEIJER	VARIOUS PROGRAM SUPPLIES	01-20-4353 5.45	01/31/2025	5.45
Total MEIJER:					5.45
<b>Melisa Martinez</b>					
MM030325	Melisa Martinez	PROGRAM - PAPER CRAFTING - 3/3/25	01-24-4571 250.00	01/27/2025	250.00
Total Melisa Martinez:					250.00
<b>MENARDS</b>					
K6602-FEB25	MENARDS	PROGRAM SUPPLIES	01-20-4353 4.27 01-20-4353 0.00	01/31/2025	4.27
Total MENARDS:					4.27
<b>Michael Marschalk</b>					
MM011425	Michael Marschalk	FACILITIES MILEAGE: 4/2/24-11/15/24	01-10-4171 60.10	01/14/2025	60.10
Total Michael Marschalk:					60.10
<b>MICHAELS</b>					
N8770-FEB25	MICHAELS	PAINTING SUPPLIES	01-24-4353 25.98	01/31/2025	25.98
N8770-FEB25	MICHAELS	TEEN CRAFT SUPPLIES	01-24-4353 130.32	01/31/2025	130.32
N8770-FEB25	MICHAELS	ART SUPPLIES	01-27-4353 62.94	01/31/2025	62.94
Total MICHAELS:					219.24
<b>Midwest Tape</b>					
506560698	Midwest Tape	ADULT MUSIC	01-26-4550 129.35	01/02/2025	129.35
506560699	Midwest Tape	ADULT DVD	01-26-4557 182.90	01/02/2025	182.90
506560730	Midwest Tape	ADULT DVD	01-26-4557 182.90	01/02/2025	182.90
506560731	Midwest Tape	JUVENILE DVD	01-26-4558 38.47	01/02/2025	38.47
506560732	Midwest Tape	JUVENILE DVD	01-26-4558 19.53	01/02/2025	19.53
506560733	Midwest Tape	ADULT DVD	01-26-4557 30.88	01/02/2025	30.88
506560734	Midwest Tape	ADULT DVD	01-29-4557 32.41	01/02/2025	32.41
506560735	Midwest Tape	JUVENILE DVD	01-29-4558 27.32	01/02/2025	27.32
506560736	Midwest Tape	ADULT DVD	01-26-4557 67.48	01/02/2025	67.48
506560691	Midwest Tape	ADULT MUSIC	01-26-4550 21.18	01/02/2025	21.18
506560692	Midwest Tape	ADULT MUSIC	01-26-4550 141.44	01/02/2025	141.44
506560694	Midwest Tape	ADULT MUSIC	01-26-4550 32.06	01/02/2025	32.06
506560695	Midwest Tape	JUVENILE DVD	01-26-4558 77.14	01/02/2025	77.14

FOUNTAINDALE PUBLIC LIBRARY DISTRICT  
 BILLS PAYABLES REPORT  
 FEBRUARY 20, 2025

Invoice Number	Vendor Name	Description	Distributions\Amounts		Invoice Date	Inv Amt
<b>Midwest Tape</b>						
506560696	Midwest Tape	ADULT DVD	01-26-4557	97.23	01/02/2025	97.23
506560697	Midwest Tape	ADULT DVD	01-26-4557	97.23	01/02/2025	97.23
506560978	Midwest Tape	ADULT DVD	01-26-4557	(5.70)	01/02/2025	(5.70)
506577946	Midwest Tape	ADULT MUSIC	01-26-4550	18.74	01/06/2025	18.74
506578594	Midwest Tape	JUVENILE DVD	01-26-4558	20.41	01/08/2025	20.41
506578595	Midwest Tape	ADULT DVD	01-26-4557	20.41	01/08/2025	20.41
506578596	Midwest Tape	ADULT DVD	01-26-4557	43.48	01/08/2025	43.48
506578597	Midwest Tape	ADULT DVD	01-26-4557	118.71	01/08/2025	118.71
506578598	Midwest Tape	ADULT DVD	01-26-4557	64.82	01/08/2025	64.82
506578599	Midwest Tape	ADULT DVD	01-26-4557	64.82	01/08/2025	64.82
506586760	Midwest Tape	JUVENILE DVD	01-26-4558	49.82	01/08/2025	49.82
506586761	Midwest Tape	JUVENILE DVD	01-26-4558	101.30	01/08/2025	101.30
506586762	Midwest Tape	ADULT DVD	01-26-4557	31.66	01/08/2025	31.66
506586763	Midwest Tape	ADULT DVD	01-26-4557	45.32	01/08/2025	45.32
506586764	Midwest Tape	JUVENILE DVD	01-26-4558	20.41	01/08/2025	20.41
506586765	Midwest Tape	ADULT DVD	01-26-4557	94.50	01/08/2025	94.50
506586766	Midwest Tape	ADULT DVD	01-26-4557	69.48	01/08/2025	69.48
506586767	Midwest Tape	ADULT DVD	01-26-4557	46.82	01/08/2025	46.82
506586768	Midwest Tape	ADULT DVD	01-26-4557	179.79	01/08/2025	179.79
506586769	Midwest Tape	ADULT DVD	01-26-4557	64.01	01/08/2025	64.01
506586770	Midwest Tape	ADULT DVD	01-26-4557	38.27	01/08/2025	38.27
506586771	Midwest Tape	JUVENILE DVD	01-29-4558	20.41	01/08/2025	20.41
506586772	Midwest Tape	ADULT DVD	01-26-4557	103.34	01/08/2025	103.34
506619091	Midwest Tape	JUVENILE DVD	01-26-4558	43.07	01/15/2025	43.07
506619092	Midwest Tape	ADULT MUSIC	01-26-4550	33.86	01/15/2025	33.86
506619093	Midwest Tape	ADULT DVD	01-26-4557	48.32	01/15/2025	48.32
506619094	Midwest Tape	JUVENILE DVD	01-26-4558	28.98	01/15/2025	28.98
506619095	Midwest Tape	ADULT DVD	01-26-4557	96.64	01/15/2025	96.64
506619096	Midwest Tape	ADULT DVD	01-26-4557	138.49	01/15/2025	138.49
506619097	Midwest Tape	ADULT DVD	01-26-4557	82.99	01/15/2025	82.99
506619098	Midwest Tape	ADULT MUSIC	01-26-4550	19.33	01/15/2025	19.33
506619099	Midwest Tape	JUVENILE DVD	01-26-4558	43.07	01/15/2025	43.07
506619100	Midwest Tape	ADULT DVD	01-26-4557	131.46	01/15/2025	131.46
506619101	Midwest Tape	ADULT DVD	01-26-4557	131.46	01/15/2025	131.46
506619102	Midwest Tape	ADULT DVD	01-26-4557	181.44	01/15/2025	181.44
506619103	Midwest Tape	ADULT DVD	01-26-4557	26.83	01/15/2025	26.83
506619104	Midwest Tape	ADULT MUSIC	01-26-4550	120.31	01/15/2025	120.31
506619105	Midwest Tape	ADULT DVD	01-26-4557	92.73	01/15/2025	92.73
506619106	Midwest Tape	ADULT MUSIC	01-26-4550	49.89	01/15/2025	49.89
506619107	Midwest Tape	ADULT DVD	01-26-4557	92.73	01/15/2025	92.73
506619108	Midwest Tape	ADULT DVD	01-26-4557	97.23	01/15/2025	97.23
506619109	Midwest Tape	ADULT DVD	01-26-4557	182.90	01/15/2025	182.90
506619110	Midwest Tape	ADULT DVD	01-26-4557	27.91	01/15/2025	27.91
506619111	Midwest Tape	ADULT DVD	01-26-4557	97.23	01/15/2025	97.23
506619112	Midwest Tape	ADULT DVD	01-26-4557	182.90	01/15/2025	182.90
506619113	Midwest Tape	ADULT DVD	01-26-4557	162.05	01/15/2025	162.05
506619114	Midwest Tape	ADULT DVD	01-26-4557	182.90	01/15/2025	182.90
506619115	Midwest Tape	ADULT DVD	01-26-4557	162.05	01/15/2025	162.05
506619116	Midwest Tape	ADULT DVD	01-26-4557	182.90	01/15/2025	182.90
506619117	Midwest Tape	ADULT DVD	01-26-4557	49.99	01/15/2025	49.99

FOUNTAINDALE PUBLIC LIBRARY DISTRICT  
 BILLS PAYABLES REPORT  
 FEBRUARY 20, 2025

Invoice Number	Vendor Name	Description	Distributions\Amounts		Invoice Date	Inv Amt
<b>Midwest Tape</b>						
506619118	Midwest Tape	ADULT MUSIC	01-26-4550	32.06	01/15/2025	32.06
506619119	Midwest Tape	ADULT DVD	01-26-4557	84.99	01/15/2025	84.99
506619120	Midwest Tape	ADULT DVD	01-26-4557	84.99	01/15/2025	84.99
506619121	Midwest Tape	ADULT DVD	01-26-4557	39.42	01/15/2025	39.42
506619122	Midwest Tape	ADULT DVD	01-26-4557	197.10	01/15/2025	197.10
506619123	Midwest Tape	ADULT MUSIC	01-26-4550	33.41	01/15/2025	33.41
506619124	Midwest Tape	ADULT DVD	01-26-4557	64.82	01/15/2025	64.82
506619125	Midwest Tape	ADULT DVD	01-26-4557	64.82	01/15/2025	64.82
506619126	Midwest Tape	ADULT DVD	01-26-4557	46.92	01/15/2025	46.92
506619127	Midwest Tape	ADULT DVD	01-26-4557	44.28	01/15/2025	44.28
506619128	Midwest Tape	JUVENILE DVD	01-26-4558	24.16	01/15/2025	24.16
506619129	Midwest Tape	ADULT DVD	01-26-4557	145.87	01/15/2025	145.87
506619130	Midwest Tape	ADULT DVD	01-26-4557	58.88	01/15/2025	58.88
506619131	Midwest Tape	ADULT DVD	01-29-4557	69.48	01/15/2025	69.48
506619132	Midwest Tape	ADULT DVD	01-29-4557	61.82	01/15/2025	61.82
506619133	Midwest Tape	ADULT DVD	01-29-4557	64.82	01/15/2025	64.82
506619134	Midwest Tape	ADULT DVD	01-29-4557	32.41	01/15/2025	32.41
506619135	Midwest Tape	JUVENILE DVD	01-29-4558	18.91	01/15/2025	18.91
506619136	Midwest Tape	ADULT DVD	01-26-4557	32.88	01/15/2025	32.88
506619137	Midwest Tape	ADULT DVD	01-26-4557	71.76	01/15/2025	71.76
506619138	Midwest Tape	ADULT DVD	01-26-4557	34.05	01/15/2025	34.05
506619139	Midwest Tape	ADULT DVD	01-26-4557	67.73	01/15/2025	67.73
506619140	Midwest Tape	ADULT DVD	01-29-4557	82.73	01/15/2025	82.73
506619141	Midwest Tape	ADULT DVD	01-26-4557	59.47	01/15/2025	59.47
506501632	Midwest Tape	ADULT MUSIC	01-26-4550	73.12	12/19/2024	73.12
506501633	Midwest Tape	ADULT DVD	01-26-4557	133.71	12/19/2024	133.71
506501634	Midwest Tape	ADULT MUSIC	01-26-4550	16.03	12/19/2024	16.03
506501635	Midwest Tape	ADULT DVD	01-26-4557	43.92	12/19/2024	43.92
506501636	Midwest Tape	JUVENILE DVD	01-26-4558	126.64	12/19/2024	126.64
506501637	Midwest Tape	ADULT MUSIC	01-26-4550	33.13	12/19/2024	33.13
506501638	Midwest Tape	ADULT DVD	01-26-4557	114.64	12/19/2024	114.64
506501639	Midwest Tape	ADULT DVD	01-26-4557	61.98	12/19/2024	61.98
506501640	Midwest Tape	ADULT DVD	01-26-4557	48.66	12/19/2024	48.66
506501641	Midwest Tape	ADULT DVD	01-26-4557	70.00	12/19/2024	70.00
506501642	Midwest Tape	ADULT MUSIC	01-26-4550	34.01	12/19/2024	34.01
506501643	Midwest Tape	JUVENILE DVD	01-26-4558	409.45	12/19/2024	409.45
506501644	Midwest Tape	ADULT DVD	01-26-4557	19.66	12/19/2024	19.66
506501645	Midwest Tape	ADULT DVD	01-26-4557	46.92	12/19/2024	46.92
506501646	Midwest Tape	ADULT MUSIC	01-26-4550	20.83	12/19/2024	20.83
506501648	Midwest Tape	ADULT DVD	01-26-4557	21.91	12/19/2024	21.91
506501649	Midwest Tape	ADULT DVD	01-26-4557	46.92	12/19/2024	46.92
506501650	Midwest Tape	ADULT DVD	01-26-4557	21.91	12/19/2024	21.91
506501651	Midwest Tape	ADULT MUSIC	01-26-4550	26.28	12/19/2024	26.28
506501652	Midwest Tape	ADULT MUSIC	01-26-4550	18.58	12/19/2024	18.58
506501653	Midwest Tape	ADULT DVD	01-26-4557	23.41	12/19/2024	23.41
506501654	Midwest Tape	JUVENILE DVD	01-29-4558	58.23	12/19/2024	58.23
506501655	Midwest Tape	ADULT DVD	01-26-4557	48.73	12/19/2024	48.73
506501656	Midwest Tape	ADULT DVD	01-26-4557	63.18	12/19/2024	63.18
506501657	Midwest Tape	ADULT DVD	01-26-4557	34.28	12/19/2024	34.28
506501658	Midwest Tape	ADULT DVD	01-26-4557	71.48	12/19/2024	71.48

FOUNTAINDALE PUBLIC LIBRARY DISTRICT  
 BILLS PAYABLES REPORT  
 FEBRUARY 20, 2025

Invoice Number	Vendor Name	Description	Distributions\Amounts	Invoice Date	Inv Amt
<b>Midwest Tape</b>					
506518627	Midwest Tape	ADULT MUSIC	01-26-4550 20.69	12/23/2024	20.69
506530205	Midwest Tape	ADULT DVD	01-26-4557 20.41	12/26/2024	20.41
506530206	Midwest Tape	JUVENILE DVD	01-26-4558 24.16	12/26/2024	24.16
506530207	Midwest Tape	ADULT MUSIC	01-26-4550 17.83	12/26/2024	17.83
506530208	Midwest Tape	JUVENILE DVD	01-26-4558 75.48	12/26/2024	75.48
506530209	Midwest Tape	ADULT MUSIC	01-26-4550 376.20	12/26/2024	376.20
506530291	Midwest Tape	ADULT MUSIC	01-26-4550 20.83	12/26/2024	20.83
506530292	Midwest Tape	ADULT DVD	01-26-4557 27.91	12/26/2024	27.91
506530293	Midwest Tape	ADULT DVD	01-26-4557 25.66	12/26/2024	25.66
506530294	Midwest Tape	ADULT DVD	01-26-4557 108.80	12/26/2024	108.80
506530295	Midwest Tape	JUVENILE DVD	01-26-4558 676.42	12/26/2024	676.42
506530296	Midwest Tape	ADULT DVD	01-26-4557 181.12	12/26/2024	181.12
506530297	Midwest Tape	ADULT DVD	01-26-4557 122.25	12/26/2024	122.25
506530298	Midwest Tape	ADULT MUSIC	01-26-4550 36.01	12/26/2024	36.01
506530299	Midwest Tape	ADULT DVD	01-26-4557 24.44	12/26/2024	24.44
506530300	Midwest Tape	ADULT DVD	01-26-4557 32.67	12/26/2024	32.67
506530301	Midwest Tape	ADULT DVD	01-26-4557 18.16	12/26/2024	18.16
506530302	Midwest Tape	ADULT DVD	01-26-4557 42.00	12/26/2024	42.00
506530303	Midwest Tape	JUVENILE DVD	01-29-4558 92.39	12/26/2024	92.39
506530304	Midwest Tape	ADULT DVD	01-26-4557 29.13	12/26/2024	29.13
506530305	Midwest Tape	ADULT DVD	01-26-4557 71.23	12/26/2024	71.23
506677478	Midwest Tape	ADULT DVD	01-26-4557 21.91	01/29/2025	21.91
506677479	Midwest Tape	ADULT MUSIC	01-26-4550 15.13	01/29/2025	15.13
506678221	Midwest Tape	ADULT DVD	01-26-4557 147.37	01/29/2025	147.37
506678222	Midwest Tape	ADULT MUSIC	01-26-4550 35.66	01/29/2025	35.66
506678223	Midwest Tape	ADULT DVD	01-26-4557 148.71	01/29/2025	148.71
506678224	Midwest Tape	ADULT DVD	01-26-4557 129.93	01/29/2025	129.93
506678225	Midwest Tape	ADULT DVD	01-26-4557 24.33	01/29/2025	24.33
506678226	Midwest Tape	ADULT DVD	01-26-4557 61.23	01/29/2025	61.23
506678227	Midwest Tape	ADULT DVD	01-26-4557 24.16	01/29/2025	24.16
506678228	Midwest Tape	JUVENILE DVD	01-26-4558 33.32	01/29/2025	33.32
506678229	Midwest Tape	ADULT DVD	01-26-4557 35.53	01/29/2025	35.53
506678230	Midwest Tape	ADULT DVD	01-26-4557 40.82	01/29/2025	40.82
506678231	Midwest Tape	ADULT DVD	01-26-4557 55.82	01/29/2025	55.82
506678232	Midwest Tape	ADULT DVD	01-26-4557 162.05	01/29/2025	162.05
506678233	Midwest Tape	ADULT DVD	01-26-4557 190.40	01/29/2025	190.40
506678234	Midwest Tape	ADULT DVD	01-26-4557 162.05	01/29/2025	162.05
506678235	Midwest Tape	ADULT DVD	01-26-4557 190.40	01/29/2025	190.40
506678236	Midwest Tape	JUVENILE DVD	01-26-4558 70.23	01/29/2025	70.23
506678237	Midwest Tape	ADULT DVD	01-26-4557 83.34	01/29/2025	83.34
506678238	Midwest Tape	ADULT DVD	01-26-4557 36.33	01/29/2025	36.33
506678239	Midwest Tape	JUVENILE DVD	01-26-4558 52.82	01/29/2025	52.82
506678240	Midwest Tape	JUVENILE DVD	01-29-4558 16.66	01/29/2025	16.66
506678241	Midwest Tape	ADULT DVD	01-29-4557 64.82	01/29/2025	64.82
506678242	Midwest Tape	ADULT DVD	01-26-4557 34.55	01/29/2025	34.55
506678243	Midwest Tape	ADULT DVD	01-26-4557 41.24	01/29/2025	41.24
506649791	Midwest Tape	ADULT MUSIC	01-26-4550 36.86	01/23/2025	36.86
506649793	Midwest Tape	ADULT MUSIC	01-26-4550 54.99	01/23/2025	54.99
506649794	Midwest Tape	ADULT MUSIC	01-26-4550 54.24	01/23/2025	54.24
506649795	Midwest Tape	ADULT DVD	01-26-4557 57.48	01/23/2025	57.48

FOUNTAINDALE PUBLIC LIBRARY DISTRICT  
BILLS PAYABLES REPORT  
FEBRUARY 20, 2025

Invoice Number	Vendor Name	Description	Distributions\Amounts	Invoice Date	Inv Amt
<b>Midwest Tape</b>					
506649796	Midwest Tape	ADULT MUSIC	01-26-4550 99.83	01/23/2025	99.83
506649797	Midwest Tape	ADULT DVD	01-26-4557 24.16	01/23/2025	24.16
506649798	Midwest Tape	ADULT DVD	01-26-4557 124.90	01/23/2025	124.90
506649799	Midwest Tape	JUVENILE DVD	01-26-4558 98.54	01/23/2025	98.54
506649800	Midwest Tape	ADULT DVD	01-26-4557 50.26	01/23/2025	50.26
506649801	Midwest Tape	ADULT DVD	01-26-4557 45.32	01/23/2025	45.32
506649802	Midwest Tape	ADULT DVD	01-26-4557 219.85	01/23/2025	219.85
506649803	Midwest Tape	JUVENILE DVD	01-26-4558 161.62	01/23/2025	161.62
506649804	Midwest Tape	ADULT DVD	01-26-4557 25.13	01/23/2025	25.13
506649805	Midwest Tape	ADULT DVD	01-26-4557 24.16	01/23/2025	24.16
506649806	Midwest Tape	ADULT MUSIC	01-26-4550 18.58	01/23/2025	18.58
506649807	Midwest Tape	ADULT MUSIC	01-26-4550 28.46	01/23/2025	28.46
506649808	Midwest Tape	ADULT DVD	01-26-4557 101.73	01/23/2025	101.73
506649809	Midwest Tape	ADULT DVD	01-26-4557 120.99	01/23/2025	120.99
506649810	Midwest Tape	ADULT DVD	01-26-4557 50.57	01/23/2025	50.57
506649811	Midwest Tape	ADULT DVD	01-26-4557 120.99	01/23/2025	120.99
506649812	Midwest Tape	ADULT MUSIC	01-26-4550 14.08	01/23/2025	14.08
506649813	Midwest Tape	ADULT DVD	01-26-4557 24.16	01/23/2025	24.16
506649814	Midwest Tape	ADULT DVD	01-26-4557 152.77	01/23/2025	152.77
506649815	Midwest Tape	ADULT DVD	01-26-4557 52.33	01/23/2025	52.33
506649816	Midwest Tape	ADULT MUSIC	01-29-4550 14.23	01/23/2025	14.23
506649817	Midwest Tape	ADULT DVD	01-29-4557 33.91	01/23/2025	33.91
506649818	Midwest Tape	ADULT DVD	01-26-4557 248.94	01/23/2025	248.94
506649819	Midwest Tape	ADULT DVD	01-29-4557 108.98	01/23/2025	108.98
Total Midwest Tape:					14,374.05
<b>MISC VENDORS</b>					
0000373078	FORMS+SURFACES	MEETING RM D RECEPTACLES & PARTS	01-30-4391 1,318.00 01-30-4391 50.00 01-30-4391 1,165.00 01-30-4391 380.00	01/20/2025	2,913.00
IS6826	INDRE SKULTINAS	REFUND: "TROLLS BAND TOGETHER"	01-10-3310 26.99	01/22/2025	26.99
MS9725-1	MARJORIE SANCHEZ	REFUND: "BUGS!"	01-10-3310 5.59	01/22/2025	5.59
MS9725-2	MARJORIE SANCHEZ	REFUND: "GRAY WOLVES"	01-10-3310 10.77	01/22/2025	10.77
K6602-FEB25	ETSY	PROGRAM PRINTS	01-20-4353 3.14	01/31/2025	3.14
K6602-FEB25	WALMART	PROGRAM SUPPLIES	01-20-4353 11.97	01/31/2025	11.97
K6602-FEB25	TEACHERS PAY TEACHERS	PROGRAM SUPPLIES	01-20-4353 5.50 01-20-4353 5.00 01-20-4353 5.00	01/31/2025	15.50
3742	AMAZON	PROGRAM SUPPLIES	01-20-4353 11.97	01/31/2025	11.97
P9444-FEB25	SELEFINA SPICES	SPICE CLUB SUPPLIES	01-28-4353 10.00 01-28-4353 10.00 01-28-4353 10.00 01-28-4353 3.75	01/31/2025	33.75
P9444-FEB25	GOLDEN CARERS	SENIOR PROGRAM RESOURCES	01-28-4353 59.99	01/31/2025	59.99
P2117-FEB25	ABT	STAFF LOUNGE MICROWAVE	08-30-4211 169.00	01/31/2025	169.00
N8770-FEB25	DUNKIN DONUTS	ADULT WINTER READING PRIZES	01-24-4353 50.00	01/31/2025	50.00
N8770-FEB25	PUPPETNERD.COM	PUPPET PATTERNS	01-27-4353 195.00	01/31/2025	195.00
N8770-FEB25	INNOVATIVE USERS GROUP	THEOBALD CONF: 3/13/25-3/15/25	01-10-4151 450.00	01/31/2025	450.00

**FOUNTAINDALE PUBLIC LIBRARY DISTRICT  
BILLS PAYABLES REPORT  
FEBRUARY 20, 2025**

Invoice Number	Vendor Name	Description	Distributions\Amounts	Invoice Date	Inv Amt
<b>MISC VENDORS</b>					
N8770-FEB25	ZENDESK	ANNUAL SUPPORT PROFESSIONAL SUBSCRIPTION	01-14-4631 2,521.92	01/31/2025	2,521.92
N8770-FEB25	ZOOM	ANNUAL WORKPLACE PRO SUBSCRIPTION	01-14-4631 449.70 01-14-4631 1,440.00	01/31/2025	1,889.70
N8770-FEB25	DUPAGE GENEALOGICAL SOCIETY	DUDEK DGS CONF: 3/1/25	01-10-4151 95.00	01/31/2025	95.00
N8770-FEB25	RENTALS UNLIMITED	STAFF IN-SERVICE CHAIRS: 2/28/25	01-10-4353 150.00 01-10-4353 46.00	01/31/2025	196.00
N8770-FEB25	PDQ.COM	ANNUAL LICENSES RENEWALS	01-14-4631 80.10 01-14-4631 80.10	01/31/2025	160.20
M4566-FEB25	THE KINETIC DANCE COMPANY	DANCING W/ STARS BB TICKETS	01-16-4173 232.56 01-10-4173 174.42	01/31/2025	406.98
T7780-FEB25	SOUTHWEST AIRLINES	THEOBALD IUG 2025 CONF. AIRFARE	01-10-4171 343.92	01/31/2025	343.92
T7780-FEB25	WALSWORTH YEARBOOKS	2025 BHS YEARBOOKS	01-26-4541 130.00 01-26-4541 7.98	01/31/2025	137.98
85010200011	GOOD OLD DAYS	PERIODICALS	01-29-4511 17.95	01/03/2025	17.95
Total MISC VENDORS:					9,726.32
<b>NANCY BOOKER</b>					
NB030825	NANCY BOOKER	PROGRAM - SUBURBAN PARANORMAL SHOWCASE - 3/8/25	01-24-4571 100.00	10/19/2024	100.00
Total NANCY BOOKER:					100.00
<b>NETFLIX</b>					
P9444-FEB25	NETFLIX	4/8 OUTREACH ROKU MONTHLY SUBSCRIPTIONS	01-26-4523 22.99	01/31/2025	22.99
P9444-FEB25	NETFLIX	2/8 OUTREACH ROKU MONTHLY SUBSCRIPTIONS	01-26-4523 22.99	01/31/2025	22.99
P9444-FEB25	NETFLIX	2/8 OUTREACH ROKU MONTHLY SUBSCRIPTIONS	01-26-4523 22.99	01/31/2025	22.99
N8770-FEB25	NETFLIX	4/12 ADDITIONAL ROKU MONTHLY SUBSCRIPTIONS	01-26-4523 22.99	01/31/2025	22.99
N8770-FEB25	NETFLIX	4/12 ADDITIONAL ROKU MONTHLY SUBSCRIPTIONS	01-26-4523 22.99	01/31/2025	22.99
M4566-FEB25	NETFLIX	4/12 ADDITIONAL ROKU MONTHLY SUBSCRIPTIONS	01-26-4523 22.99	01/31/2025	22.99
T7780-FEB25	NETFLIX	4/12 ROKU MONTHLY SUBSCRIPTIONS	01-26-4523 22.99	01/31/2025	22.99
T7780-FEB25	NETFLIX	4/12 ROKU MONTHLY SUBSCRIPTIONS	01-26-4523 22.99	01/31/2025	22.99
T7780-FEB25	NETFLIX	4/12 ROKU MONTHLY SUBSCRIPTIONS	01-26-4523 22.99	01/31/2025	22.99
Total NETFLIX:					206.91
<b>NEXTERA ENERGY SERVICES MIDWEST LLC</b>					
G4044080110	NEXTERA ENERGY SERVICES MIDWEST LLC	GAS SERVICE: 12/1/24-12/31/24	01-30-4322 3,296.31	01/14/2025	3,296.31
Total NEXTERA ENERGY SERVICES MIDWEST LLC:					3,296.31
<b>Pace Systems, Inc.</b>					
IN00063617	Pace Systems, Inc.	ADDITIONAL SECURITY CAMERAS	08-30-4211 2,738.00	12/31/2024	2,738.00
216105	Pace Systems, Inc.	CCTV 2025 PLATINUM RENEWAL	01-30-4392 5,865.00	01/24/2025	5,865.00
216117	Pace Systems, Inc.	MEETING RM D CABLE INSTALLATION	08-30-4211 661.42	01/31/2025	661.42

FOUNTAINDALE PUBLIC LIBRARY DISTRICT  
 BILLS PAYABLES REPORT  
 FEBRUARY 20, 2025

Invoice Number	Vendor Name	Description	Distributions\Amounts	Invoice Date	Inv Amt
<b>Pace Systems, Inc.</b>					
Total Pace Systems, Inc.:					9,264.42
<b>PANERA BREAD</b>					
N8770-FEB25	PANERA BREAD	PINNACLE STRATEGIC MEETING: REFRESHMENTS	01-10-4715 41.18	01/31/2025	41.18
N8770-FEB25	PANERA BREAD	JAN. 2025 DONUTS W/ DIRECTOR REFRESHMENTS	01-10-4715 10.59	01/31/2025	10.59
Total PANERA BREAD:					51.77
<b>PARANORMAL MOMS SOCIETY</b>					
PMS030825	PARANORMAL MOMS SOCIETY	PROGRAM - SUBURBAN PARANORMAL SHOWCASE - 3/8/25	01-24-4571 100.00	12/13/2024	100.00
Total PARANORMAL MOMS SOCIETY:					100.00
<b>PARTIES WITH CHARACTER</b>					
PC060425DEP OSIT	PARTIES WITH CHARACTER	PROGRAM DEPOSIT - SPIDER GWEN TRAINING - 6/4/25	01-28-4572 155.00	01/28/2025	155.00
Total PARTIES WITH CHARACTER:					155.00
<b>PAUL JEFFREY SCHMIDT</b>					
PJS030825	PAUL JEFFREY SCHMIDT	PROGRAM - SUBURBAN PARANORMAL SHOWCASE - 3/8/25	01-24-4571 100.00	01/24/2025	100.00
Total PAUL JEFFREY SCHMIDT:					100.00
<b>Peerless Network, Inc.</b>					
67973	Peerless Network, Inc.	TELEPHONE: 1/15/25-2/14/25	01-14-4312 444.54	01/15/2025	444.54
Total Peerless Network, Inc.:					444.54
<b>PeopleFacts</b>					
33754-012025	PeopleFacts	NEW HIRE BACKGROUND CHECKS: JAN. 2025	01-10-4253 98.32	02/01/2025	98.32
Total PeopleFacts:					98.32
<b>PETTY CASH - COLLECTIONS</b>					
1059	PETTY CASH - COLLECTIONS	ADULT NONFICTION BOOKS	01-26-4541 60.00	06/12/2024	60.00
Total PETTY CASH - COLLECTIONS:					60.00
<b>Playaway Products LLC</b>					
485241	Playaway Products LLC	JUVENILE EASY BOOKS	01-26-4546 56.04	12/18/2024	56.04
485280	Playaway Products LLC	YOUNG ADULT AUDIOBOOKS	01-26-4555 233.87	12/18/2024	233.87
485824	Playaway Products LLC	JUVENILE PLAYAWAY BOOKS	01-29-4562 445.42	12/26/2024	445.42
485827	Playaway Products LLC	ADULT AUDIOBOOKS	01-26-4551 438.54	12/26/2024	438.54
485829	Playaway Products LLC	JUVENILE AUDIOBOOKS	01-26-4553 788.58	12/26/2024	788.58
486768	Playaway Products LLC	JUVENILE LAUNCHPADS	01-26-4566 436.97	01/09/2025	436.97
488203	Playaway Products LLC	JUVENILE LAUNCHPADS	01-26-4566 74.99	01/22/2025	74.99
488211	Playaway Products LLC	JUVENILE LAUNCHPADS	01-26-4566 74.99	01/22/2025	74.99
488112	Playaway Products LLC	ADULT AUDIOBOOKS	01-26-4551 467.44	01/22/2025	467.44
488224	Playaway Products LLC	PROCESSING & MENDING SUPPLIES	01-12-4371 8.75 01-26-4518 9.95	01/22/2025	18.70
488534	Playaway Products LLC	JUVENILE AUDIOBOOKS	01-26-4553 774.57	01/24/2025	774.57
488537	Playaway Products LLC	JUVENILE PLAYAWAY BOOKS	01-29-4562 439.06	01/24/2025	439.06
488573	Playaway Products LLC	JUVENILE LAUNCHPADS	01-26-4566 793.20	01/24/2025	793.20
Total Playaway Products LLC:					5,042.37



FOUNTAINDALE PUBLIC LIBRARY DISTRICT  
 BILLS PAYABLES REPORT  
 FEBRUARY 20, 2025

Invoice Number	Vendor Name	Description	Distributions\Amounts	Invoice Date	Inv Amt
<b>Plunkett's</b>					
8995107	Plunkett's	PEST CONTROL: JAN. 2025	08-30-4215 118.98	01/28/2025	118.98
Total Plunkett's:					118.98
<b>REACHING ACROSS ILLINOIS LIBRARY SYSTEMS (RAILS)</b>					
13731	REACHING ACROSS ILLINOIS LIBRARY SYSTEMS	SWANK MOVIE LICENSE: 1/1/25-12/31/25	01-24-4571 265.00 01-24-4573 265.00 01-20-4572 265.00	01/09/2025	795.00
Total REACHING ACROSS ILLINOIS LIBRARY SYSTEMS (RAILS):					795.00
<b>Sandy Andes</b>					
SA012825	Sandy Andes	CIRC MILEAGE: 8/3/24 & 12/7/24	01-10-4171 10.39	01/28/2025	10.39
Total Sandy Andes:					10.39
<b>Sebert Landscaping Inc.</b>					
285036	Sebert Landscaping Inc.	SNOW MAINTENANCE: JAN. 2025	01-30-4392 3,019.00	01/01/2025	3,019.00
287292	Sebert Landscaping Inc.	SNOW MAINTENANCE: FEB. 2025	01-30-4392 3,019.00	02/01/2025	3,019.00
S597569	Sebert Landscaping Inc.	RESTOCK ICE MELT	08-30-4357 332.00	01/24/2025	332.00
Total Sebert Landscaping Inc.:					6,370.00
<b>Shaw Media</b>					
012510071633	Shaw Media	2025 BB CHAMBER DIRECTORY & GUIDE AD	01-10-4731 755.00	01/31/2025	755.00
Total Shaw Media:					755.00
<b>Showcases</b>					
329723	Showcases	PROCESSING & MENDING SUPPLIES	01-12-4371 35.55 01-12-4371 26.10 01-26-4518 4.93	11/27/2024	66.58
329827	Showcases	PROCESSING & MENDING SUPPLIES	01-12-4371 801.00 01-26-4518 64.08	12/19/2024	865.08
Total Showcases:					931.66
<b>Skokie Public Library</b>					
228114072	Skokie Public Library	LOST/DAMAGED: "AMERICAN SHTETL"	01-10-3311 25.00	12/03/2024	25.00
Total Skokie Public Library:					25.00
<b>SPOTIFY</b>					
N8770-FEB25	SPOTIFY	MONTHLY PATRON STREAMING MUSIC	01-14-4631 19.99	01/31/2025	19.99
Total SPOTIFY:					19.99
<b>Stage Lighting Store, LLC</b>					
495895	Stage Lighting Store, LLC	STUDIO SPOTLIGHT STOCK	08-30-4357 270.62	01/22/2025	270.62
Total Stage Lighting Store, LLC:					270.62
<b>Susan K Maddox</b>					
SKM031325	Susan K Maddox	PROGRAM - COOKING W/ CHEF MADDUX - 3/13/25	01-24-4571 375.00	02/07/2025	375.00
Total Susan K Maddox:					375.00
<b>SYLVIA SHULTS</b>					

**FOUNTAINDALE PUBLIC LIBRARY DISTRICT  
BILLS PAYABLES REPORT  
FEBRUARY 20, 2025**

Invoice Number	Vendor Name	Description	Distributions\Amounts	Invoice Date	Inv Amt
<b>SYLVIA SHULTS</b>					
SS030825	SYLVIA SHULTS	PROGRAM - SUBURBAN PARANORMAL SHOWCASE - 3/8/25	01-24-4571 100.00	12/09/2024	100.00
Total SYLVIA SHULTS:					100.00
<b>SYSTEM WIDE AUTOMATED NETWORK (SWAN)</b>					
LS2518	SYSTEM WIDE AUTOMATED NETWORK (SWAN)	LOST/DAMAGED: "ABBY & ELMO'S AMAZING ADVENTURES"	01-10-3311 17.00	01/01/2025	17.00
Total SYSTEM WIDE AUTOMATED NETWORK (SWAN):					17.00
<b>TARGET</b>					
N8770-FEB25	TARGET	PROGRAM SUPPLIES	01-27-4353 55.93	01/31/2025	55.93
T7780-FEB25	TARGET	PROCESSING & MENDING SUPPLIES	01-12-4371 14.94	01/31/2025	14.94
Total TARGET:					70.87
<b>Taylor Plumbing, Inc</b>					
35680	Taylor Plumbing, Inc	2025 RPZ TESTING	08-30-4211 1,119.50	02/05/2025	1,119.50
Total Taylor Plumbing, Inc:					1,119.50
<b>TDI VERTICAL</b>					
INV1608	TDI VERTICAL LLC	VMWARE SOFTWARE LICENSE: 3/14/25-3/13/26	01-14-4631 14,900.80	02/06/2025	14,900.80
Total TDI VERTICAL:					14,900.80
<b>Terryberry</b>					
S35782	Terryberry	EMPLOYEE RECOGNITION: 15 YEARS	01-10-4153 194.88 01-10-4153 27.51	01/07/2025	222.39
S38553	Terryberry	EMPLOYEE RECOGNITION KITS & PINS	01-10-4153 339.57 01-10-4153 482.67 01-10-4153 38.43	01/14/2025	860.67
Total Terryberry:					1,083.06
<b>THE LANGUAGE LABS</b>					
TLL022425	THE LANGUAGE LABS	PROGRAM - NOCHE DE LA FAMILIA - 2/24/25	01-20-4572 195.00	12/09/2024	195.00
TLL030325	THE LANGUAGE LABS	PROGRAM - NOCHE DE LA FAMILIA - 3/3/25	01-20-4572 195.00	12/09/2024	195.00
TLL031725	THE LANGUAGE LABS	PROGRAM - NOCHE DE LA FAMILIA - 3/17/25	01-20-4572 195.00	12/09/2024	195.00
Total THE LANGUAGE LABS:					585.00
<b>The New York Times</b>					
088705314	The New York Times	PERIODICALS	01-26-4511 1,101.50	12/22/2024	1,101.50
Total The New York Times:					1,101.50
<b>THE OFFICE OF THE STATE FIRE MARSHAL</b>					
9705814	THE OFFICE OF THE STATE FIRE MARSHAL	BOILER CERTIFICATE FEES: INSPECTION 1/23/25	08-30-4211 210.00	01/24/2025	210.00
Total THE OFFICE OF THE STATE FIRE MARSHAL:					210.00
<b>Today's Business Solutions, Inc.</b>					
127264	Today's Business Solutions, Inc.	FAX PROGRAM: OCT. - DEC. 2024	01-14-4234 223.68	01/28/2025	223.68
Total Today's Business Solutions, Inc.:					223.68

FOUNTAINDALE PUBLIC LIBRARY DISTRICT  
 BILLS PAYABLES REPORT  
 FEBRUARY 20, 2025

Invoice Number	Vendor Name	Description	Distributions\Amounts	Invoice Date	Inv Amt
<b>Tressler LLP</b>					
500854	Tressler LLP	DEC. 2024 ATTORNEY LEGAL EXPENSE	01-10-4241 253.00	01/10/2025	253.00
500855	Tressler LLP	DEC. 2024 ATTORNEY LEGAL EXPENSE	01-10-4241 1,775.50	01/10/2025	1,775.50
Total Tressler LLP:					2,028.50
<b>Tria Architecture, Inc.</b>					
5568	Tria Architecture, Inc.	MONUMENT SIGN RENO: CONSTRUCTION DOCS	06-10-4681 1,846.87	02/05/2025	1,846.87
Total Tria Architecture, Inc.:					1,846.87
<b>U.S. BANK EQUIPMENT FINANCE</b>					
548388651	U.S. BANK EQUIPMENT FINANCE	LEASED EQUIPMENT: 2/28/25-3/30/25	01-14-4234 3,596.59	02/04/2025	3,596.59
Total U.S. BANK EQUIPMENT FINANCE:					3,596.59
<b>Ulster Historical Foundation</b>					
UHF031725	Ulster Historical Foundation	PROGRAM - IRISH GENEALOGY WORKSHOP - 3/17/25	01-24-4571 500.00 01-10-4575 250.00	01/30/2025	750.00
UHF031825	Ulster Historical Foundation	PROGRAM - IRISH GENEALOGY WORKSHOP - 3/18/25	01-24-4571 500.00 01-10-4575 250.00	01/30/2025	750.00
Total Ulster Historical Foundation:					1,500.00
<b>Unique Management Services, Inc.</b>					
6134522	Unique Management Services, Inc.	COLLECTION SERVICES: DEC. 2024	01-10-4245 531.90	01/01/2025	531.90
6135277	Unique Management Services, Inc.	NEW MOVER POSTCARDS: DEC. 2024	01-10-4256 232.50	01/03/2025	232.50
6135673	Unique Management Services, Inc.	COLLECTION SERVICES: JAN. 2025	01-10-4245 443.25	02/01/2025	443.25
Total Unique Management Services, Inc.:					1,207.65
<b>USCutter</b>					
100525756	USCutter	VARIOUS VINYL	01-27-4371 147.99 01-24-4353 65.99	01/31/2025	213.98
Total USCutter:					213.98
<b>Verizon Wireless</b>					
6103799423	Verizon Wireless	TELEPHONE: 12/17/24-1/16/25	01-14-4311 539.88	01/16/2025	539.88
Total Verizon Wireless:					539.88
<b>Village of Bolingbrook</b>					
74016	Village of Bolingbrook	ANNUAL ELEVATOR INSPECTION: 11/8/24	08-30-4215 225.00	01/13/2025	225.00
Total Village of Bolingbrook:					225.00
<b>Warehouse Direct</b>					
5854948-1	Warehouse Direct	DISTRICT RESTOCK: DEC. 2024	08-30-4357 36.08	01/10/2025	36.08
5856344-0	Warehouse Direct	PROGRAM COLORED TAPE	01-20-4353 15.69	01/08/2025	15.69
5871215-0	Warehouse Direct	PAPER PRODUCT RESTOCK: JAN. 2025	08-30-4357 449.64 08-30-4357 132.34 08-30-4357 95.01 08-30-4357 216.52 08-30-4357 43.45	01/31/2025	936.96

FOUNTAINDALE PUBLIC LIBRARY DISTRICT  
 BILLS PAYABLES REPORT  
 FEBRUARY 20, 2025

Invoice Number	Vendor Name	Description	Distributions\Amounts	Invoice Date	Inv Amt
<b>Warehouse Direct</b>					
Total Warehouse Direct:					988.73
<b>WOOBX</b>					
<a href="#">N8770-FEB25</a>	WOOBX	MONTHLY SUBSCRIPTION	01-10-4731      29.00	01/31/2025	29.00
Total WOOBOX:					29.00
<b>ZORO TOOLS</b>					
<a href="#">INV1565687</a>	ZORO TOOLS	REPLACEMENT SIGN	01-30-4392      5.29 01-30-4392      120.99 01-30-4392      163.99	01/30/2025	290.27
<a href="#">INV15656374</a>	ZORO TOOLS	REPLACEMENT SIGN POST	01-30-4392      125.99 01-30-4392      110.00	01/30/2025	235.99
Total ZORO TOOLS:					526.26
Report Total:					287,813.34



Jennie Nguyen/Finance Manager

# January 2025 Monthly Board Report

## Executive Director (Paul Mills)

### Pinnacle Library Cooperative (PLC) Strategic Plan Update

The PLC Strategic Plan Group met earlier this month and reviewed the work done in 2024. Key highlights include solidifying a schedule for regular training workshops, creating onboarding training for new hires and committee members, establishing procedures for potential new member libraries with cost and policies, and working on standardizing circulation settings to increase patron satisfaction.

Looking ahead, projects for 2025 include offering a training menu with options to request particular training, creating quarterly training forums for particular staff groups, exploring having a Pinnacle Staff Day in 2026, and working on the Pinnacle Website/Intranet in 2025.

## Deputy Director (Nancy Korczak)

In January we had a great partnership by hosting a table from the Illinois Tollway Authority. The staff were very friendly and our patrons were happy to have the service here being able to get the new iPass sticker and deactivate their transponders. The service was so popular that they returned a second time in January and will be here in February, March and April.

We also had staff from both Senator Loughran Cappel and Representative Avelar host office hours in our lobby. Our patrons always appreciate these office hours and enjoy checking in with the staff. The library will continue to look for more opportunities to partner with elected officials and government organizations to bring service to the library for our patrons.

# Adult & Teen Services Report (Debra Dudek)

## Department Summary

- ATSD staff began implementing a new programming Basecamp project
- ATSD staff conducted an audit of available supplies and purchasing list
- ATSD staff received two positive comment cards this month, complimenting our team for their assistance with technical assistance and computer commons printing.
- Self-serve computer passes continue to receive positive feedback at the departmental desks
- An additional final round of editing the departmental procedure manual was conducted.

## Adult Programming Highlights

- Winter Reading Program participation has garnered a strong following of 131 adult patrons logging their reading.
- 'The Beatles, Chicago and the 1960s' virtual program with Dr. John F. Lyons on Wednesday, January 29 garnered 38 participants. Our patrons really connect with this era of music and entertainment.
- Top Programs - SCORE Workshop (90), Chef Maddox Cozy, Comfort One-Pan Meals (40), The Beatles, Chicago and the 1960s (38), & Senior Social: Lucy! An Original Musical (35).
- Summer and fall programming planning continues for 'Level Up at Your Library' Summer Adventure, 'Golden Girls Gathering' in August, Five Nights of Halloween in October, and a Salute to World War II Veterans in November.

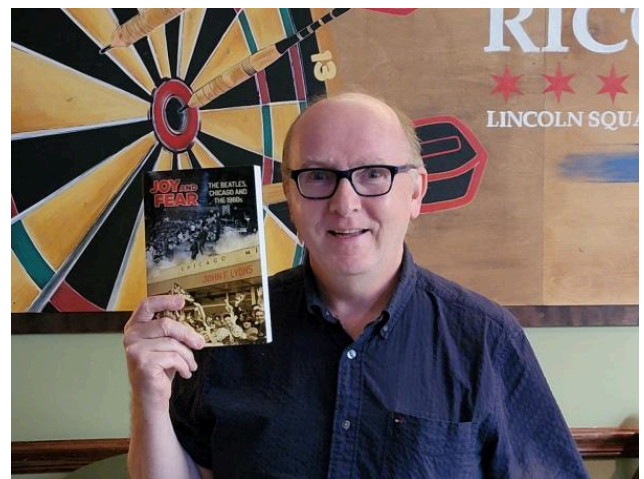

## Teen Programming Highlights

- Randi and Haley hosted a middle school outreach craft program connecting with 313 patrons
- Crafts continue to garner strong support from our middle grade students.
- Teen programs with the top attendance this month were Middle School Outreach Crafts (313), Teen Volunteering Book Reviews (57), Puzzle Palooza (29), Question of the Week (27), Teen Winter Reading Challenge (27), Cozy Felted Cat Craft Time (15), and DIY Backpack Charms (9).



## Department Statistics

- One student has completed 84% of their Career Online High School coursework.

# Children's Services (Joyce Arellano)

## Department Summary

- In addition to our successful Reading Dragons & Friends program, CSD launched the 2025 Winter Reading Challenge this month. The challenge uses a game board-style reading log, and children can read or complete different activities to move across the board. Many thanks to the Friends of the Library for donating vouchers for a free book as a completion prize.
- Our service desk saw another busy month of questions. Staff helped our young friends find the latest *Dog Man* title, winter books, phonics books and more. We also registered patrons for upcoming programs and signed up children for all our reading programs!
- Our newer staff attended several orientations offered by other managers and learned about Collection Services, Outreach Services and the Vortex.
- We celebrated two staff members' anniversaries this month. Congratulations to Children's Services Assistant Manager, Melissa F., for 2 years of service! Congratulations to Children's Services Specialist, Arielle, for 1 year of service!

## Programming Highlights

- A new season of storytimes began this month. We will offer 17 storytimes per week through early May in addition to the events we will offer for older children and families.
- To start the new season of Sensory Storytime, Sarah D. and Rachel presented Sensory Night: Let's Build! for children with autism, neurodivergence and physical disabilities. "I had a family say how she appreciated having these events as a good 'reintroduction' to the library and storytimes for her kiddo after our breaks." *Rachel O.* "I didn't realize how much I was smiling during this program until Rachel shared her photos! Kids were really engaged with the different building options." *Sarah D.*

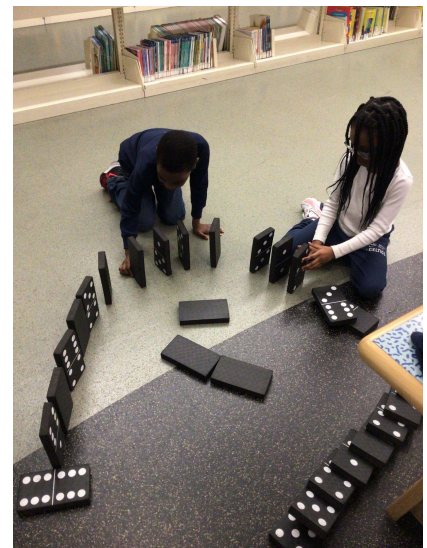



- In anticipation of the movie release, Chris and Deanna presented a *Dog Man* Party for 88 patrons! "A huge turnout! We had many stations for the kids to enjoy. The kids were so excited when I opened the door they ran in like shoppers on Black Friday." *Chris Z.* "While leaving the program, I overheard a parent on the phone say they were just leaving the *Dog Man* party at the library and her child was 'going crazy and having so much fun.'" *Deanna J.*



## Department Statistics

- 1,466 patrons attended CSD's 86 active (synchronous) programs.
- 369 patrons participated in 6 passive (asynchronous) programs.
- 305 children in grades K–5 are participating in Reading Dragons & Friends. This month we signed up 70 new children!
- 208 babies, toddlers and preschoolers are participating in 1000 Books Before Kindergarten. This month 10 new children signed up, and 1 child completed the program.
- 611 reference questions were answered.
- 447 directional questions were answered.
- 17 one-on-one instruction sessions were completed.

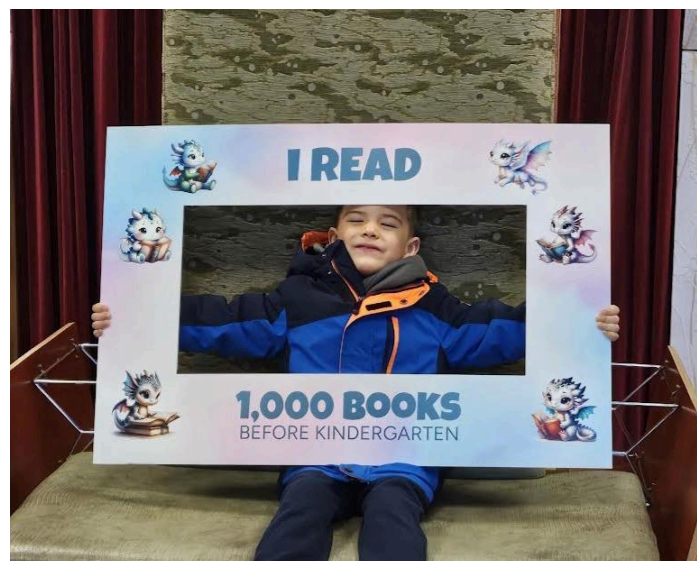

# Circulation Services (Jacob Luce)

## Department Summary

- Collaborated with Collection Services and Communications to help launch the Hold, Please! author subscription service. This is an excellent service for our patrons to automatically get placed on hold for newly released materials from their favorite authors.
- Our IT department fixed our 3M gate counter, which is now giving an accurate patron count again.
- The new shelf-cleaning cart has arrived. This cart will house cleaning supplies so the Aides can help clean the library shelving. They will start on the 3rd floor and work their way down.
- The Aides began working on the Juvenile Nonfiction shifting project. They shifted the materials to create open bays for additional windowing and to rebalance the collection.
- The AMH was having issues with the diverter rollers and was not sorting materials properly. After some in-house troubleshooting, a Lyngsoe tech had to come out and replace two of the modules in one of the sorter's power boxes. This solved the issue, and the AMH is sorting properly again.
- The monthly AMH cleaning took place.
- The Department Manager and Assistant Manager conducted interviews for the open Specialist position.
- The Associate Manager and a Lead Specialist conducted interviews for the open Aide position. A candidate accepted an offer and will start in February.

## Department Statistics

- 158 new library cards were issued in person, and 66 patrons signed up for library cards online.
- 123 license plate stickers were renewed, a 7% increase from January 2024.
- 562 visitors came to our drive-thru, a decrease of 16% from January 2023's total of 675 visits.
- 2,691 items were checked out through our drive-thru.
- 1,111 items were checked out through the On-site Lockers.
- 102 items were checked out through the BRAC Lockers.

# Collection Services (Christina Theobald)

## Department Summary

- This month we launched a new service called *Hold, Please!* It is an auto-hold subscription service where patrons can subscribe and automatically get placed on hold for the newest book releases by their favorite authors. Patrons can choose from a selection of 80 popular authors and can subscribe through an online webform or by filling out a paper brochure, available in the Lobby, 2nd and 3rd floor service desks. This service allows patrons to set it and forget it, while we do the rest! In less than a week since its launch, we have already received 27 patron subscriptions and wonderful positive feedback!

Thank you to our task force members, Lynnette Hopwood (Adult Collection Librarian), Jacob Luce (Circulation Manager), and Steven Ford (Digital Communications Administrator) for their hard work in helping to create and maintain this service. Additional special thanks to Melissa Bradley (Communications Manager) and Sabrina Smallwood (Communications Design Specialist).



- Lily and I attended a PinDigital Committee meeting hosted here at Fountindale. We further discussed the Cost Per Circ lending model and decided to utilize this model for expired metered titles. The committee also discussed bestseller ordering and agreed to order carts a day earlier on Tuesdays instead of Wednesdays. This is in efforts to have copies available as they are released on Tuesdays without any further delays and fulfill patrons' holds even faster.
- Brett worked with Circulation staff to shift the Juvenile Nonfiction collection and create windowed bays at the beginning of each Dewey class. This allows us to showcase more materials face-out, and serves as visual indicators for what nonfiction subjects are found in each row of shelving. The additional windowing already proves to be working, as Juvenile Nonfiction circulation increased 9% compared to last year!



## Department Statistics

- 3,231 new items were added to the collection.
- 3,285 old and worn items were withdrawn from circulation.
- 314 incoming interlibrary loans were processed for our patrons.
- 88 outgoing interlibrary loans were shared with other libraries.
- 407 items were repaired, 316 invoices were paid and 351 boxes were received.
- 102 original bibliographic records were cataloged.
- 5.3% of collection is considered “dead”, defined as items that have not circulated in 2 years. We are under the standard recommendation of less than 10% dead.
- 7.3% of collection is considered “grubby”, defined as having circulated 75 times or more. We are under the standard recommendation of less than 10% grubby.

## Collection Highlights

- 4.5% increase in physical circulation, totaling 2,276 more circs than last year.
- Digital circulation was 20.5% of the library’s total circulation.
- Juvenile Graphic Novels experienced the highest positive circulation growth, with 718 more circs and a 28% increase. Following in circulation growth was Movies & TV and Picture Books with 633 and 514 more circs respectively.
- Juvenile Video Games, Juvenile Nonfiction and Juvenile Audiobooks also experienced significant positive circulation growth.
- Picture Books and Movies & TV were the two most popular collections, having the most circs compared to the other collections. Following in popularity were the Adult Fiction and Adult Nonfiction collections.
- 1,378 circulations were yielded from 40 displays. The most popular were the Lobby displays *Get Organized* and *New Year, Same You*, as well as CSD’s *1,000 Books Before Kindergarten* and *Dragons* displays.
- The most popular adult books were *Now or Never: Thirty-One and On the Run* by Janet Evanovich and *Maame* by Jessica George. The most popular picture book was *I Love My New Toy!* by Mo Willems. The most popular movie was *Joker : Folie à Deux*.

## Circulation by Branch

Branch	Jan 2024	Jan 2025	Change	% Changed
Building	44313	44520	207	0.47%
Outreach	4582	6726	2144	46.79%
Studio	1724	1649	-75	-4.35%
Digital	14829	13618	-1211	-8.17%
<b>Totals</b>	<b>65448</b>	<b>66513</b>	<b>1065</b>	<b>1.63%</b>

## Digital Collection Usage

Digital Platform	Jan 2024	Jan 2025	Change	% Changed
Hoopla	3180	3762	582	18.30%
Libby	8258	8287	29	0.35%
Boundless	242	231	-11	-4.55%
PressReader	328	256	-72	-21.95%
Kanopy	701	611	-90	-12.84%
Freegal	2120	471	-1649	-77.78%
<b>Totals</b>	<b>14829</b>	<b>13618</b>	<b>-1211</b>	<b>-8.17%</b>



# Communications (Melissa Bradley)

## Department Highlights

- Our Google Ads had 15,289 impressions and 2,017 clicks.
  - Campaigns with the most impressions:
    - Digital Media: 7,208 impressions; 1,108 clicks
    - Kanopy: 3,404 impressions; 303 clicks
    - Catalog Items: 1,872 impressions; 76 clicks
- We auto-renewed 46 library cards with Patron Point.
- We scheduled, wrote/edited and published 11 blog posts.
- Melissa and Sabrina held a Staff Picks filming session.
- Melissa met with ArchiveSocial to learn how to archive job postings on social media for five years instead of the standard three.
- Melissa met with Elena and Tasos to discuss transitioning staff over to new ID badges.
- Melissa designed the Bolingbrook Black History Month Awareness Club's community event program book.
- The entire Communications team helped support the launch of Hold, Please!, our author new release auto-hold subscription service. Steven served on the task force and created the web forms and pages, Melissa came up with the name and designed the promotional materials and Sabrina created the brochure.
- Sabrina completed the spring issue of *The Fountain*. She also designed the Hold, Please! Brochure, worked on design concepts for this year's Summer Adventure theme and created all of the collateral for Black History Month.



- Sandford, John
- Score, Lory
- Scottoline, Lisa
- Shavis, Jill
- Slaughter, Karin
- Sparks, Nicholas
- Steet, Danielle
- Thor, Brad
- Ware, Ruth
- Williams, Beatriz
- Yarros, Rebecca

Please return your completed form to any Fountaindale Library service desk or the Bookmobile. If you need to update your list of authors or unsubscribe, please complete a new form or visit [fountaindale.org/holdplease](http://fountaindale.org/holdplease).

You must be a Fountaindale Public Library cardholder to participate.

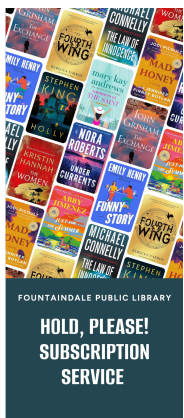



## Media Coverage

- [The Patch](#) mentioned us in their Winterfest coverage.
- [The Patch](#) mentioned our Smart Strategies for Downsizing event.

## Social Media Metrics

### Facebook

- 79 new followers
- 4,129 page views
- 106,998 people viewed our content (reach)
- 1,000 engagements (likes, comments, clicks, saves & shares)

### Instagram

- 0 new followers
- 377 post engagements (likes, comments, saves & shares)
- 9,015 people viewed our content (reach)
- 12,278 reels views

### TikTok

- 20 new followers
- 920 post engagements (likes, comments & shares)
- 13,352 views

### YouTube

- 6 videos & 6 shorts published
- 28 new subscribers (1,851 total)
- 9,231 views
- 257.1 hours of watch time
- 53,476 impressions (video thumbnails shown to viewers)

# Email Marketing Metrics

## MailChimp Blogs:

- 3,970 subscribers
- Average open rate: 37.6% (industry average is 21.33%)
- Average click rate: 1.57% (industry average is 2.62%)

## Patron Point:

- Average open rate: 66.81% (industry average is 21.33%)
- Average click rate: 19.25% (industry average is 2.62%)

# Facilities Operations (Tasos Priovolos)

## Department Summary

- We continued with the LED lighting project. Most long lead-time items arrived and the contractor is working through installing the lights and controls. This project is being completed early in the morning in order to minimize impact to staff and patrons.
- Working with the architect and civil engineer to finalize designs of an updated property drain system and resurface the parking lot.
- Working with the architect and designers to finalize designs of a new monument sign and display for the Briarcliff entrance.
- We had our annual backflow device inspections and tests completed this past month. These inspections assure that the devices which prevent dirty water going back to the water supply are functioning properly.
- We had our annual emergency light inspection completed this month. This inspection assures that all emergency lighting will operate for a predetermined amount of time during an emergency or power outage.

## Zendesk

In January, 55 new maintenance tickets were created, and 56 new or existing tickets were completed.

# Finance (Jennie Nguyen)

## Highlights

### Record Retention

Jennifer Flores of Lauterbach & Amen provided an on-site training session for our management team on January 13, 2025. Jennifer provided an overview of the record retention process and guidelines that need to be followed. This session provided the opportunity for the managers to ask questions and clarify on what needs to be done. The current approved record retention application has been posted to the staff intranet site for staff to review.

Jennifer also conducted the Library's annual review of the District's financial records and disposed of records that have met the parameters of the State approved disposal certificate. Allyse Schiller (Finance) and Liz Scheiner (Collections) were able to move records to the Archive Room in preparation for the next year's record retention process.

### Finance Liaison Meeting

The Executive Director and I met with two members of the Board, Celeste Bermejo (Board President) and Kathy Spindel (Board Treasurer). During the meeting we discussed the current status of the Library's financial records as of the end of the last quarter of the fiscal year, December 31, 2024. At all liaison meetings, an audit is conducted, which includes a random selection of payable records, much like what our auditors normally conduct during our annual audit. Records are reviewed to determine if all of the physical records match the digital records with proper authorization.

### BS&A Software

I have been in contact with the BS&A Software team to review the current platform for report and record accessibility. Some privilege parameters have been customized to restrict access to sensitive information to adhere to the Library's Identity Protection Policy. The software users will be updated with the new privileges.

To improve the document accessibility for the financial reports, I have reached out to the BS & A Software team to determine if the software provides an overall update option that would improve the accessibility of the document. Unfortunately, there is not a cross-the-board option. Some reports can be updated, and other reports can not be revised due to them being a system-created report. Those reports would need to be custom created. The Finance team will be working to create customized reports for key financial reports as we move forward.

# Human Resources (Elena Flores)

## Recruitment

### Open Positions

- Accounts Payable Coordinator - Candidate Selected
- Circulation Services Aide - Candidate Selected
- Circulation Services Specialist - Accepting Applications
- Security Guard/ Customer Service - Accepting Applications

## Training

- Payroll and Taxability Training Session - Lauterbach & Amen, LLP (Elena Flores)
- Authorized Agent Workshop - Illinois Municipal Retirement Fund (Amy Maciejewski)

## Special Projects

- Updated all online recruitment pages to include full pay range, actual starting rate, and benefits information to be compliant with the Pay Transparency Amendment to the Illinois Equal Pay Act of 2003.
- Selected a new vendor for new hire and all staff annual Anti-harassment and Anti-Discrimination training. Previous vendor sunsetted products 12/31/2024.

# Information Technology (John Matysek)

## Highlights

- During the month of January, 101 new help desk tickets were created by FPLD staff, and 90 new or existing tickets were solved by IT staff.
- Worked with vendor Cisco to update all of the wireless access points (AP's) to the latest recommended firmware version
- Along with Jose Robles, Andrew Keefe, and Ben Jansen, worked with vendor bibliotheca to troubleshoot and resolve an issue with the self checks configuration allowing patrons to check out items when their account was blocked.
- Along with Jose Robles, continued working with vendors Today's Business Solutions (TBS) and Porteus on the configuration of a new standalone public computer self service guest pass station for patron usage.
- Along with Jose Robles, Andrew Keefe, and Ben Jansen, prepared various older IT equipment items for inclusion in an upcoming public auction.
- Along with Jose Robles, Andrew Keefe, and Ben Jansen, began work on converting all of the online public access computers (OPAC's) to a new version of the Porteus Kiosk software operating system.
- Along with Jose Robles, Andrew Keefe, and Ben Jansen, worked with vendor bibliotheca to troubleshoot and resolve an issue with the RFID gates at the library entrance where the people counting function was not working properly.
- Along with Jose Robles, Andrew Keefe, and Ben Jansen, started work on converting staff computers to Windows 11 in preparation for the current Windows 10 end of support date later this year.

# Outreach Services (Tana Petrov)

## Department Summary

- Outreach hosted Bolingbrook Park District preschool classes in the library for a tour, storytime and craft. Our littlest patrons learned how to check out and return materials, and enjoyed exploring the different stations in the Children Services Department. We had 76 preschoolers and 11 teachers attend the tours.

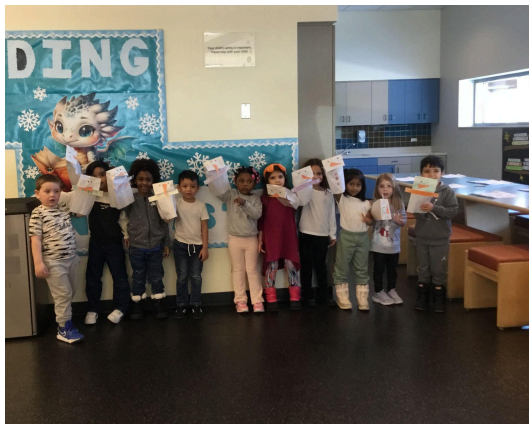

- Bookmobile patrons participated in National Stickers Month by getting a fun sticker when they checked out a book and by designing their own sticker.
- We offered Spice Kits on the Bookmobile, featuring the spice “cumin” in January and recipes from CultureGrams eResource and our digital cooking magazines.
- Outreach expanded our Student Success library cards to Bolingbrook residents who attend Woodridge School District 68. We issued cards for 130 students.
- We put together book giveaways for Pioneer Elementary PTO Read-A-Thon Program. We received a kind note: *“This is so much appreciated! So much gratitude for you guys! Our school is thankful!”*





## Programming Highlights

- Jan 8 and Jan 9: Our senior patrons at Encore and StoryPoint enjoyed an “excursion” to Australia. They listened to short stories, played trivia games and explored animal puppets about the country. Our senior patrons at Capital Care made a melted snowman in a glass vial and decorated mandala window clings.
- Jan 11: LEGO Club - 22 patrons attended; we received positive comments from kids, parents and the Bolingbrook Historical Museum.
- Jan 17: The Learning Experience Preschool STEAM event - 40 patrons visited the library table, enjoying books and STEAM activities.



## Department Statistics

- 17 new home delivery patrons joined the program in 2024. Outreach made 43 more home deliveries to our patrons using this service than in 2023.
- 679 preschoolers attended a storytime.
- 1310 patrons visited our outreach vehicles.
- 2916 students attended a booktalk.

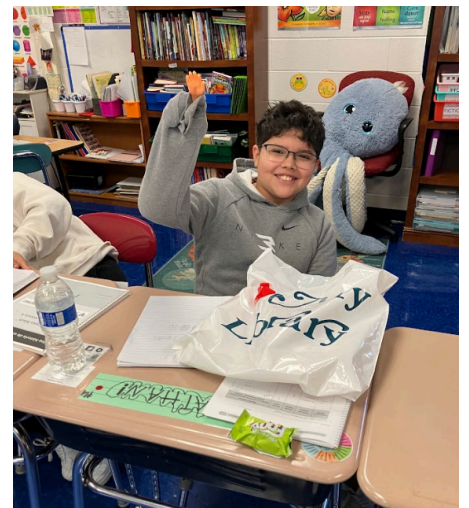

# Studio 300 (Jacinto Gonzalez)

## Department Summary

January 2025 in Studio 300, marked a rise in interest in creative programs like embroidery, sublimation, and 3D printing. Patrons of all ages explored new techniques and equipment, with standout programs like Puzzle Palooza drawing 28 teens and the Sublimation Embroidery Teen Class receiving enthusiastic feedback. Memorable patron interactions included a patron working on digitizing family cassette tapes with the Hi8 camera, who expressed gratitude for Ericka's in-depth assistance, and a photography one-on-one where a patron felt empowered to continue learning independently after exploring the studio's camera and lighting equipment. Staff members also made significant strides in professional development, with Ruth completing Domestika courses on scriptwriting and environmentally conscious photography, and Connor learning the sublimation printing process for his upcoming March program.

## Programming Highlights

- **“Live Loops in Logic Pro” (Jack):**

A mix of beginners and experienced users attended, highlighting the need for clearer skill-level descriptions for future programs. Patrons left inspired to continue learning.

- **Sublimation Embroidery Teen Class (Adriana and Randi):**

Five teens learned the basics of sublimation and embroidery, creating personalized projects. The event was well-received, with teens asking about future programs with sublimation.

- **Tabletop Photography Class (Adriana):**

Nine patrons explored the studio's cameras and lighting options, with beginners learning photography basics and experienced users refining their skills.

**Puzzle Palooza (Adriana):** 28 teens enjoyed puzzles and snacks in a relaxed, social setting.

- **Film Club (Adriana):** Six patrons discussed the 1960 film Magnificent Seven, sparking lively conversations.

- **Winter Wonderland Embroidery Scenes (Ruth):** Patrons created holiday-themed embroidery designs using the studio's resources.

- **“Meet the Heat Presses” (Monica):** Introduced patrons to heat press equipment and its creative applications.



- **Fountaindale Writers Group (Jacinto):** The writer's group returned after the winter break and people shared writings whose theme was “hope.” There was also news that a writer from the group got signed by an agent and her book will be published and printed in 2026.

## Department Statistics

### Equipment Upgrades:

- **3D Printer:** Updated Creality 3D printer Flat Cable and Motor Limit Cable.
- **Vacuum Former:** The Studio got a vacuum former and plans to have it available for patrons to use soon.
- **Sewing Machine:** We have had a surge of sewing machine circulation and to help with the demand a new sewing machine was purchased.

### Studio Room Usage:

- **Audio Booths:** 67 uses with 88 total attendance.
- **Studio GCR:** 100 uses with 132 total attendance.
- **Studio Video Suites:** 52 uses with 98 total attendance.

**Total One-on-Ones Hosted:** 19

**Total Programs Offered:** 10

# Fountaindale Public Library January 2025

## Statistics

### Membership

- Active cardholders: 33,319
- New cardholders: 332
- Total visits: 22,675

### Circulation

Building	Bookmobile	Lockers	Digital	Total
45,058 (67.7%)	6,624 (10%)	1,213 (1.8%)	13,618 (20.5%)	66,513

### Interlibrary Loan

- Items received for patrons: 314
- Items sent to other libraries: 88

### Collection

- Total physical items owned: 219,362
- New physical items added: 3,231

### Programming

#### Programs Offered

Children	Teens	Adults	Cross-Departmental	Online	Total
234	49	57	0	6	346

## Program Attendance

Children	Teens	Adults	Cross-Departmental	Online	Total
5,212	612	669	0	9,231	15,724

## Reference

Directional Questions	Reference Questions	One-on-One Sessions
1,598	3,130	245

## Spaces

Meeting Room Usage	Study Room Usage	Studio Room Usage
68	485	219

## Technology

Wireless sessions	Computer usage	Website visits
16,714	2,565	29,293

## Social Media

Facebook Likes	Instagram Followers	TikTok Followers
6,099	1,999	1,209

## Comparisons

Comparison	This Year	Last Year	% Change
Circulation	66,513	65,448	<b>1.63%</b>
Visitors	22,675	21,482	<b>5.55%</b>
Cardholders	33,319	32,709	<b>1.86%</b>
Room Bookings	772	640	<b>20.63%</b>
Reference Questions	3,130	3,274	<b>-4.40%</b>
Computer Usage	2,565	2,435	<b>5.34%</b>
Wi-Fi	16,714	14,755	<b>13.28%</b>
Programs	15,724	11,659	<b>34.87%</b>